

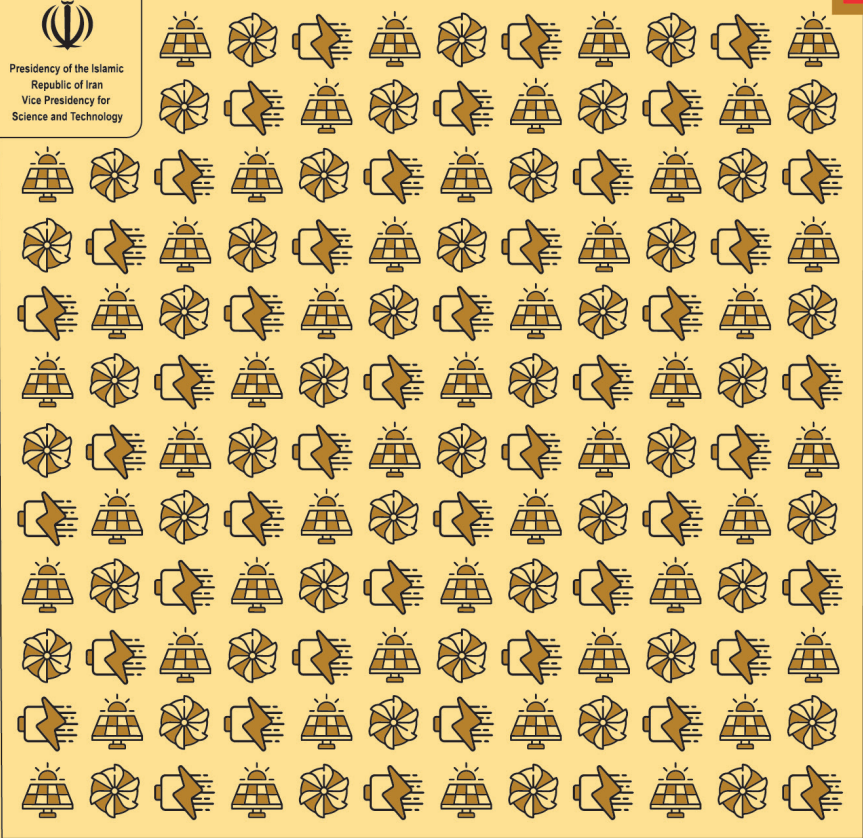

Presidency of the Islamic
Republic of Iran
Vice Presidency for
Science and Technology



Eleventh Volume

ENERGY & POWER PLANT INDUSTRIES

Knowledge-Based Products and Equipment

مجلس المدینة العلمیة

Knowledge-Based Products and Equipment
Energy & Power Plant Industries





Presidency of the Islamic
Republic of Iran Vice Presidency for
Science and Technology

— www.isti.ir —



— www.cistc.ir —



Export Development &
Technology Transfer Fund

— www.etdf.ir —



— www.ihit-expo.com —

Knowledge-Based Products and Equipment Eleventh Volume: **Energy & Power Plant Industries**

Supervisor:	Export Development and Technology Transfer Fund (ETDF)
Email:	info@etdf.ir
Website:	www.etdf.ir
Tel:	(+98) 21 910 700 80
Address:	No 4, Eram Alley, North Shirazi St., Mollasadra St., Vanak, Tehran, Iran, P.O BOX 1991734784

Preface

One of the key factors in a nation's industrialization and economic complexity is technology. Complex economies can connect vast networks of individuals with relevant information to produce a variety of knowledge-based goods. Indeed, the types of goods or products that are ultimately supplied to international markets are taken into account when determining the complexity of an economy.

A knowledge-based economy is one in which the application of knowledge and information plays a significant role in shaping production and distribution, and where investments in knowledge-based businesses have drawn particular attention. Along with enhancing nations' competitiveness, the transformation of economies into knowledge-based economies has the potential to have a significant impact on international trade.

7000 knowledge-based businesses in Iran provide knowledge-based goods that are the result of the expertise and experience of professionals and university graduates. These businesses, which occasionally resemble enormous technology factories, sold more than 10\$ billion worth of goods last year and exported 1\$ billion or so to various nations. The Presidential Deputy for Science and Technology is recognized as the most significant authority for direction, leadership, and development of the technology area in Iran. It serves as a support organization for startups and knowledge-based businesses by finding and selecting these enterprises. This book, along with 19 other books, is a carefully curated selection of goods with a track record or export potential that was put together using data provided by chosen businesses for presentation to foreign clients, business people, and government and academic officials interested in using these goods. To review the company's manufacturing and distribution records, access to technical knowledge and specialized human resources, production and export capacities, and after-sales services, two specialized and commercial committees were formed separately, and each committee reviewed the products in detail with the participation of technical and commercial experts.

In this procedure, specialized committees were held with the collaboration of the experts of the center of companies and knowledge-based institutions of the Deputy for Science and Technology, headed by *Dr Reza Asadi Fard* and Coordinated by *Engineer Mojtaba Houshmandzadeh*. In addition, *Engineer Mehdi Ghaleh Noei* and *Engineer Ruhollah Estiri* presided over commercial committee meetings, which also included businessmen from the private sector, and I want to express my gratitude to these two groups for their work and assistance.

I also want to appreciate the project manager, *Zahra Afzali*, who has taken on a lot of responsibility and given close attention to the project's design and development from the beginning with innovative ideas.

I also think it's important to recognize and express my gratitude to my other colleagues for their efforts in gathering, reviewing, contacting firms, selecting, and rewriting texts, and finally editing and creating this book:

Project monitoring and editing team: *Mohammad Torabi, Fereshte Elahi*

Evaluation team: *Mojtaba Houshmandzadeh*

Editorial team: *Fatemeh Mohammadi Siani, Mohammad Matin Shirzad*

Design team: *Mohammad Hossein Pourdabbaq, Masoud Khalili*

I want to underline that the aforementioned goods may be offered in a variety of ways in the country of destination, including export of end products, export of semi-finished and assembled products at the destination, joint production in the destination country and other economic cooperation. In each of the aforementioned scenarios, the Export Development and Technology Exchange Fund is prepared to co-invest in the target countries and guarantee the purchases as a financial sponsor of knowledge-based export enterprises.

The book's conclusion also includes a list of export management firms authorized by the Deputy for Science and Technology for communication, Iran Houses of Innovation & Technology (iHiTs), located in several countries, and commercialization and technology transfer agencies. Finally, I am hoping that this book will be beneficial to the readers and provide them with a thorough grasp of Iranian technological advancements.

Regards,
Mehrdad Amani Aghdam
CEO of Export Development and Technology Transfer Fund

Contents

CHAPTER 0

Introduction

The Origin of Industry and Export in The Eyes of Iranians.....	7
Industry and Export in Today's Iran.....	8
Where the New Technologies Stand in Iran's Industry.....	9
The Status of Knowledge-Based Products in Energy & Power Plant Industries.....	10
The Division of Knowledge-Based Products in Energy & Power Plant Industries.....	12

CHAPTER 1

Turbines

MGT-70 Series of Gas Turbines.....	26
Fixed and Moving Blades of MGT-70 Gas Turbine.....	28
MGT-40 Gas Turbine.....	30
MGT-30 Gas Turbine Series.....	32
MGT-30 Mobile Turbine Series.....	34
Fixed and Moving Blades of MGT-30 Turbine.....	36
Turning Gear of MGT-75 Gas Turbine.....	38
MGT-75 Gas Turbine Gas Skid Design.....	40
A Set of V94.2 Gas Turbine Hot Parts.....	42
Construction of Gas Turbine Combustion Chamber.....	44
Construction of the Hot Gas Inner Casing of the Gas Turbine.....	46
25 MW Gas Turbine Package.....	48

PT Rotor of the GEC Gas Turbine	50
Design and Engineering of the IGT25 Gas Turbine	52
Design, Engineering and Basic Upgrading of IGT25 Gas Turbine Along	54
Design of IGT25 Gas Turbine Plant to Operate in Petrochemical Combined Cycle Mode ...	56
Design, Engineering and Reconstruction of Gas Turbine Hot Parts	58
Cold Section Spare Parts of Gas Turbines.....	60
2 KW Gas Micro-Turbine Simultaneous Generator of Electricity and Heat	62
LTE and RI Overhaul and Repairs of Gas Turbines in HGPI, CI and MI levels.....	64
Blades and Nozzles of the Hot Section of Gas Turbines	66
Blades and Nozzles of Hot Section of Gas Turbines without Core Casting.....	68
Combustion Chamber and Gas Turbine Liner	70
Electronic Fuel Control Valve (Governor)	72
Reconstruction and Repair Services of Hot Section Parts of Gas Turbine	74
Fixed and Moving Gas Turbine Blade.....	76
Control and Protection System in Two Models: Ramyar and Ramyar 2.....	78
Gas Turbine Flowmeters with Accuracy Below One Percent Gas Turbine Flowmeter.....	80
Fundamental Overhaul of SGT 100 Turbine	82
Repairing the Hot Section Parts of Neopinion and GE-F5 Turbines.....	84
PT Rotor of Solar Saturn Gas Turbine	86
Honeycomb Mesh and Seal	88
Ruston TB4000 Gas Turbine Overhaul	90
Combustion Chamber of WERKSPoor W72M Gas Turbine	92
Blades of Cold Section of Gas Turbine (Compressor) and Steam Turbine.....	94
Shroud Block Segment of Gas Turbine	96
Coreless Blades of the Hot Section of the Gas Turbine.....	98
Coreless Diaphragm of Gas Turbine	100
Updating DCS Control System and Gas Turbine Protection	102
Reconstruction and Repair of Innercasing.....	104
GE Gas Turbine Flow Divider.....	106
Fuel System of Industrial and Power Plant Turbines.....	108
Gas Turbine Rotor with RPM (3000-30000) and Power (3-25 MW)	110
Overhaul of Gas Turbines	112
Power Plant Control Cards	114
Major Repairs of Gas Turbine Model DU80L	118
Cold Section Blades of Gas Turbine and Steam Turbine Blades.....	120
Machining and Production of Gas and Steam Turbine Blades	122
Solar Turbine Control System	124
Ruston TA 1750 Gas Turbine Burner.....	126

Repair and Reconstruction Services of Gas and Steam Turbine Parts	128
Testing and Alignment Services of V94.2, GE-F9 and MHI Turbine Fuel Injectors	130
Outer Casing and Stator Casing Parts of Gas Turbines Cast	132
C-Level Overhaul of SGT 100 and SGT 600 Gas Turbines.....	134
Overhaul, Troubleshooting and Major Repairs of MAN-THM 1304 Gas Turbine	136
Overhaul, Troubleshooting and Major Repairs of SOLAR-TAURUS 70 Gas Turbine	138
160 MW MST-50C Steam Turbine.....	140
Redesigning and Manufacturing the Blades of the Low-Pressure Section of Steam Turbines	142
Steam Turbine Rim and Blade.....	144
Complete Package of Single-Stage Impulse Steam Turbines Up to 1.1 MW.....	146
Repair and Reconstruction of the Integrated Rotor (Forged) of the Steam Turbine	148
Package of Single-stage Impulse Steam Turbines with Power of Less Than 3MW	150
Machining and Production of Various Parts of Water and Steam Turbines and Impeller..	152
Online Performance Analysis of Process Turbocompressors of Petrochemical Units	154
Inspection and Failure Analysis of Process Turbocompressors of Petrochemical Units ..	156
Wind Turbine Cast Iron Parts	158
Wind Turbine Tower.....	160
Construction of KW 660 Wind Turbine Asynchronous Generator.....	162
5 kW Vertical Axis Wind Turbine	164
Simulator of Wind Turbine's Behavior	166
2-25 Inch Turbine Gas Meter	168
A Set of Hot Parts and Fixed and Moving Blades of the GT13 Turbine	170
Fixed And Moving Blades of GE-F9 Turbine.....	172
Frequency Converter for Starting Gas Power Plants (SFC).....	174
Reconstruction and Repairs of Hot Section Blades, Combustion Chamber and Turbine Liner...	176
Power Plant Air Filter with Nanofiber Technology	178
Industrial Air Filters Containing Media Modified with Polymer Nanofibers	180
Engineering Services for Failure Analysis and Turbine Blade Life Estimation	182
Parts and Overhaul of the Rotor of Steam Turbines with Power of Less than 20 MW	184
Turbine Hot Parts Including.....	186
Reconstruction and Repair of Hot Turbine Parts	188
APS and HVOF Coating Services for Turbine Parts	190
Assembly of the Rotors of GEF5 and GEF6 Turbines	192
Power Transmission Gearbox from Turbine to Compressor PHILADELPHIA 206	194
Rejuvenation and Repair of Turbine Blades, BLADE CAREER, Hot Section.....	196
Other Advanced Turbine Parts	198
Determination of Dynamic Parameters of Power Plant Components.....	200

Water and Sewage Treatment

Thermal Desalination (MED-TVC)	236
MED-TVC Water Desalinatior	238
Thermal Desalination System (MED-TVC).....	240
Distillation Screen Water Desalination	242
Wastewater Treatment Using Advanced Oxidation Methods, Electrochemical Oxidation and Electrocoagulation on an Industrial Scale	244
Industrial Wastewater Treatment Package	246
Providing Deep Water Identification Services	248

Solar Cells

Photovoltaic Solar Panel Produced	254
Transparent Titanium Dioxide Electrode	256
Crystalline TiO ₂ Sol in Ethanol.....	258
Acidic Aqueous TiO ₂ Sol	260
Nanostructured Solar Cells Making and Characterization Set.....	262
Anti-Reflective Solar Cell Coating with High Efficiency	264
Luminescent Solar Concentrator Module Using Bifacial Photovoltaic Cells.....	266
A Research Inverter Connected to the Grid.....	268
High Performance Electrolyte.....	270
Standard Electrolyte	272

Fuel Cells

Fuel Cell Stack with Design and Manufacture of Bipolar Plates, Membrane and Catalyst... 278	
Membrane Humidifier for Fuel Cell.....	280

Batteries

Nano Barium Sulfate Used in the Battery Industry.....	286
Vanadium Battery (Flow Battery)	288

Introduction

The Origin of Industry and Export in The Eyes of Iranians

The ancient land of Iran has long been the source of knowledge and industry, and Iranians have played a significant role in the development, evolution and promotion of science and human awareness. Most historians of the world believe that most of the advances in science and human civilization are owed to Iranian civilization and the most brilliant works of art and the highest industrial levels has come from the minds of Iranians. Metalworking industries, agricultural industry, pharmacy and alchemy with themes including tile glazing, carpet dyeing, fabrics and glass were some of the industries that were considered by ancient Iranians. In parallel with the special attention to the development of industry, the history of mutual trade relations between Iranians and other civilizations in East and Central Asia, Europe and Africa has a long history, and Iranians have played a significant role in the expansion of global altruism since long ago by being on the route of the Silk Road and maritime trade.

We Iranians today, like our ancestors, consider industry, art and production in our ancient land to be a transformative and constructive place, and we consider the development of technological interactions and the trade of knowledge-based industrial products with other countries as an opportunity for friendship and the expansion of ties.

Industry and Export in Today's Iran

Industrial development has a very important place in the plans and policies of the Islamic Republic of Iran due to the creation of value added, job creation, increase in exports and reduction in imports, and the transition from an economy dependent on oil and mineral raw materials to an industrial and manufacturing economy, especially an economy dependent on new technologies, is a grand plan that has been adopted for this purpose. Currently, 50% of Iran's gross domestic product is allocated to services and another 50% to industry and manufacturing, which includes 10% agriculture and food industry, 14% oil and gas industry, and 26% other manufacturing industries.

The Share of Various Activities in Iran's GDP

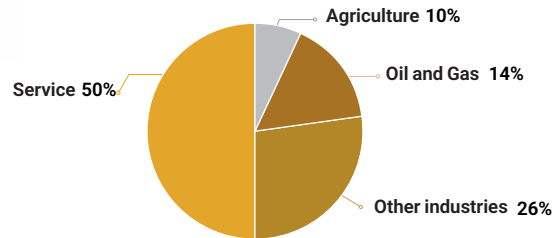

In the meantime, various industries such as pharmaceuticals, medical equipment, construction, communications and telecommunications, energy, mining, chemicals, etc. have a special share of Iran's gross domestic product, and their production, in addition to covering a considerable amount of country's domestic needs, are exported to various destinations.

According to World Customs Organization data, in 2021, the Islamic Republic of Iran had exports equal to 75 billion dollars, almost half of which is allocated to non-oil industries and processed industrial products. Advanced industrial materials, chemical intermediate products, agricultural products and food industry are all among the biggest exporting industries with more exports.

Iran's Exports in 2021

Ref: Trade Statistics for International Business Development ¹

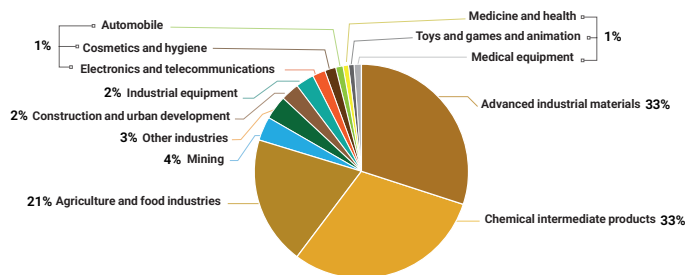

¹ www.trademap.org

Regarding the main export destinations of Iran, it should be noted that China, India, Indonesia, Russia, Uzbekistan, Ghana, Germany and South Africa, as well as among the regional neighbours, Iraq, Turkey, UAE, Afghanistan, Pakistan, Oman, Turkmenistan, and Azerbaijan account for the largest dollar value of imports from Iran.

Where the New Technologies Stand in Iran's Industry

Paying attention to the development of new technologies, commercialization and its influence on manufacturing industries has caused the Islamic Republic of Iran to experience a growing progress in this field in the last decade; An issue that has taken place in Iran in the form of the development of knowledge-based enterprises. Based on this, the meaning behind knowledge-based enterprise is as follows:

A private company that produces products or provides services that have the following three features:

1. The product or service provided by the company has a high or medium to high technology level and its technical knowledge has a significant technical complexity (technology level condition).
2. The product or service design in the company is based on internal research and development or technology transfer (Research and development-based design condition).
3. The company is able to produce and provide the mentioned goods or services to the market (production condition).

Currently, more than 7 thousand knowledge-based enterprises in Iran are producing products and providing services in the field of various technologies. These companies produce more than 15,000 products or services in total, and their direct employees, which generally include people with a high level of education, are around 250,000 people.

The Number of Knowledge-Based Companies - Technology Fields

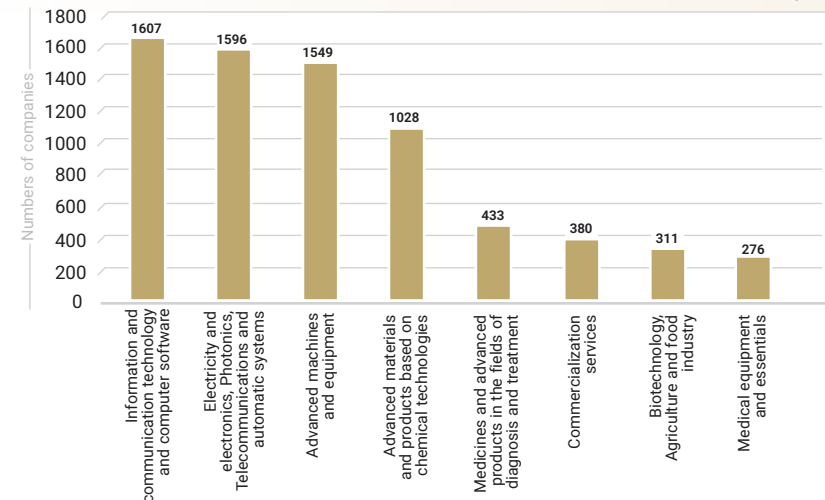

The export of Iran's knowledge-based enterprises has been growing in the last 5 years, and these companies currently account for about %2 of Iran's non-oil exports.

The Largest Export Destinations of Iranian Knowledge-Based Enterprises in the Last 5 Years

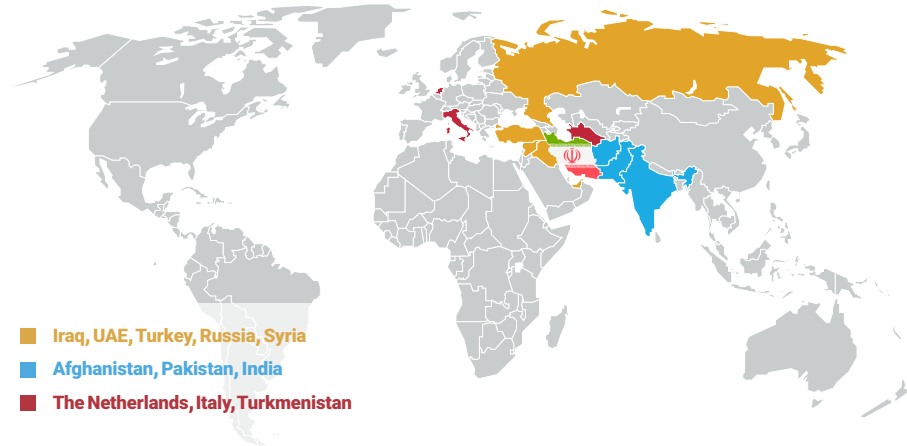

The Status of Knowledge-Based Products in Energy & Power Plant Industries

Energy industry (including all industries, organizations and companies related to energy from exploration, extraction and production to marketing, transmission and distribution of energy carriers) along with water and sewage industry (including all products and processes related to identification, supply, transmission and water treatment) are the two driving engines of industrial and social growth in any country and these two industries have had a fundamental position in the economy of the Islamic Republic of Iran for a long time.

Currently, the water, energy and power plant industries account for more than %8 of Iran's GDP, which of course can be increased by taking into account the added value of this industry in other industries.

Due to the age, volume and the basic position of these industries and their strategic nature in Iran, Iran's dry and low-water climate, and finally the many investments aimed at localization and production of the strategic technologies and equipment used therein within our own borders, this industry comprises a significant amount of activity and the production of Iranian knowledge-based companies. Currently, more than 480 Iranian knowledge enterprises that produce and supply more than 800 technological products are active in these industries. These companies account for more than %6 of Iran's

knowledge-based production and employment.

In general, regarding the export of knowledge-based products of these industries, it is worth mentioning that in the last 5 years, a total of 390 million dollars worth of products of knowledge-based companies active in the field of water, energy and power plant industries have been exported outside Iran.

The Percentage of Energy & Power Plant Industries Companies from All the Knowledge-Based Enterprises

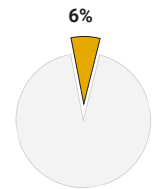

The Main Export Destinations of Iranian Knowledge-Based Enterprises in the Fields of Energy & Power Plant Industries



The Division of Knowledge-Based Products in Energy & Power Plant Industries

As previously mentioned, due to the age, volume and the fundamental position of these industries and their strategic nature in Iran, Iran's dry and low-water climate, and finally the many investments aimed at localization and production of the strategic technologies and equipment used therein within our own borders, this industry comprises a significant amount of activity and the production of Iranian knowledge-based companies and produces a wide range of products. In this regard, products have been collected in this book that can be divided into the following categories:

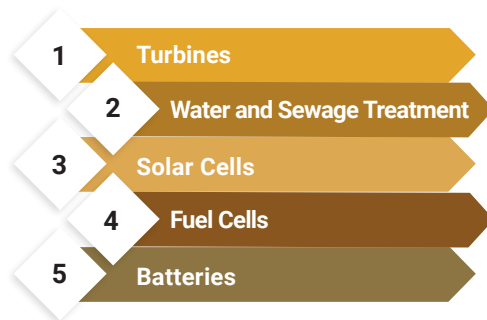

The following describes each category and their subcategories in order to give a general understanding of these areas.

1 Turbines

A turbine is generally a rotating engine that produces mechanical energy by using fluid flow or other sources and is often used to generate electrical power in combination with a generator. Various classifications have been presented for turbines. From the aspect of functional processes, two types of impulse turbine and reaction turbine can be mentioned, but the criterion for classification of turbines is their fluid type, which is as follows:

- **First Section | Gas Turbines and Their Parts:**

This type of turbine works based on the energy of gases from combustion and includes a compressor (to compress air), a combustion chamber (to mix air with fuel and ignite it) and a turbine (to convert the energy of hot and compressed gases into mechanical energy). This mechanical energy may rotate the electric generator (turbogenerator), accelerate the air (turbojet and turbofan) or directly (after changing the speed of rotation by the gearbox) be consumed in the same original form (turboshaft, turboprop and turbofan). The increasing use of gas turbines in various industries has led to the significant activity of knowledge enterprises and in this sub-category a wide range of products are included.

- **Second Section | Steam Turbines and Their Parts:**

In this type of turbines, thermal energy is extracted from steam under pressure and it is used to turn the output shaft. This turbine is suitable for starting an electric generator. Steam turbines produced by Iranian knowledge enterprises have different sizes. These turbines range from small units of 1 MW to large turbines of 160 MW. Moreover, related accessories and services are also presented in this subcategory.

- **Third Section | Wind turbines and Their Parts:**

In this sub-category, the technological capabilities of knowledge-based companies in the production of wind turbines, in which the mechanical energy of the wind is converted into electrical energy by a generator, are presented. These turbines have three main parts: tower, blades - rotor and protective cover. The tower is a long and strong structure on which other components are mounted. The material of the tower structure can be steel, cast iron or concrete. The rotor is also a rotating component to which the blades are attached and when the turbine is on, it rotates with the force of the wind. Control system, gearbox, generator and shafts are located inside the protective cover.

- **Fourth Section | Other turbine Parts and Related Services:**

In this subcategory, products such as filters used in power plant industries, various turbine parts such as blades and rotors, etc., test and control equipment and services related to turbines and power plants are included.

- **Fifth Section | Heat Transfer in Power Plants:**

In this subcategory, the equipment used for heat transfer in power plants, such as power plant heat recovery boilers, cooling systems, power plant auxiliary boilers, combustion system, water and energy resource management system, etc., which are produced by knowledge enterprises are presented.

[Start chapter at page 26](#) »

2

Water and Sewage Treatment

Treatment of water and wastewater is the concern of all countries due to the importance of healthy and hygienic water for humans as well as providing water for use in industrial processes. This issue is more important in Iran due to its dry climate. Water treatment usually includes a set of processes and branches in which the intended polluting substances in water are completely removed or reduced to an acceptable limit according to the location and type of water consumption. Related products include the following:

- **First Section | Water Desalination:**

In simple terms, non-consumable water is evaporated by using thermal energy and its salts and solutes are separated, then the water vapor turns into liquid and as a result, pure water is obtained. By adding minerals to this water, it becomes drinkable. In fact, the thermal desalination process is the same as the water cycle in nature. In this subcategory, the presented water desalinators are all made based on the MED-TVC method.

- **Second Section | Wastewater Treatment:**

Wastewater treatment is done using a wide range of methods such as physical, physical-chemical and biological methods. The use of each of these methods depends on different factors, the most important of which is the pollutants in the wastewater and the desired level of reduction of these pollutants. The products introduced in this subcategory use advanced oxidation methods, electrochemical oxidation and electrocoagulation for wastewater treatment.

- **Third Section | Deep Waters:**

Detection of and benefiting from deep waters is very important from various economic, industrial and urban aspects. In this subcategory, the products related to deep water detection services up to the test drilling phase using devices based on magnetotelluric technology are presented.

[Start chapter at page 236](#) »

3

Solar Cells

A solar cell is an electronic component that converts sunlight energy directly into electricity with the help of the photovoltaic effect. Photovoltaic cells are made of special materials called semiconductors. Cells and coatings, inverters and electrolytes can be mentioned as components of energy production from sunlight in the photovoltaic process.

- **First Section | Cells and Coatings:**

In this subcategory, various types of solar cells that are produced by knowledge enterprises and include types of silicon and titanium dioxide, are presented. High efficiency and transparency are among the positive features of these products.

- **Second Section | Inverters:**

A solar inverter is a device that converts direct current (DC) produced by solar panels into alternating current (AC) for consumers or injection into the power grid. In a photovoltaic solar system, inverters serve as the heart of the system and convert the generated DC electricity into AC.

- **Third Section | Electrolytes:**

Solid and quasi-solid electrolytes are an interesting technology for increasing of fastness of dye-sensitized solar cells. There are four main kinds of quasi solid electrolytes as thermoplastic polymers, thermosetting polymer, composites and ionic liquid polymers. Solis state electrolytes are including ionic conductors materials, inorganic hole-transfer materials and organic hole-transfer materials. The optimization of materials requires complete introduction thus.

[Start chapter at page 254](#) »

4

Fuel Cells

- **First Section | Polymer Fuel Cells:**

A fuel cell is a device that produces electricity through a chemical reaction. All fuel cells have two electrical poles (electrodes) called anode and cathode. In fact, chemical reactions take place in these electrodes and lead to the production of electricity. In this subcategory, knowledge-based products related to fuel cells are presented.

Start chapter at page 276 »

5

Batteries

- **First Section | Raw Materials for Batteries:**

Batteries are a vital and important part of human technology today, and batteries are a prerequisite for the development of many other industries. The ability of Iranian knowledge enterprises in this field is in the production of battery raw materials, which include nano barium sulfate and vanadium batteries.

Start chapter at page 286 »

Energy & Power Plant Industries

First Chapter Turbines

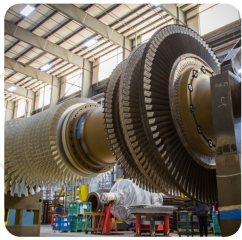

- Gas Turbines and Their Parts
- Steam Turbines and Their Parts
- Wind Turbines and Their Parts
- Other Turbine Parts and Related Services
- Heat Transfer in Power Plants

Second Chapter Water and Sewage Treatment



- Water Desalination
- Wastewater Treatment
- Deep Waters

Third Chapter Solar Cells

- Cells and Coatings
- Inverters
- Electrolytes



Fourth Chapter Fuel Cells

- Polymer Fuel Cells

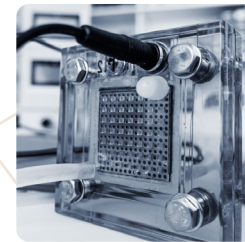

Fifth Chapter Batteries

- Raw Materials for Batteries



First Chapter Turbines



1st CHAPTER

First Chapter

Second Chapter

Third Chapter

Fourth Chapter

Fifth Chapter

Turbines

MGT-70 Series of Gas Turbines		26
Fixed and Moving Blades of MGT-70 Gas Turbine		28
MGT-40 Gas Turbine		30
MGT-30 Gas Turbine Series		32
MGT-30 Mobile Turbine Series		34
Fixed and Moving Blades of MGT-30 Turbine		36
Turning Gear of MGT-75 Gas Turbine		38
MGT-75 Gas Turbine Gas Skid Design		40
A Set of V94.2 Gas Turbine Hot Parts		42
Construction of Gas Turbine Combustion Chamber		44
Construction of the Hot Gas Inner Casing of the Gas Turbine		46
25 MW Gas Turbine Package		48
PT Rotor of the GEC Gas Turbine		50
Design and Engineering of the IGT25 Gas Turbine		52
Design, Engineering and Basic Upgrading of IGT25 Gas Turbine Along		54
Design of IGT25 Gas Turbine Plant to Operate in Petrochemical Combined Cycle Mode		56
Design, Engineering and Reconstruction of Gas Turbine Hot Parts		58
Cold Section Spare Parts of Gas Turbines		60
2 KW Gas Micro-Turbine Simultaneous Generator of Electricity and Heat		62
LTE and RI Overhaul and Repairs of Gas Turbines in HGPI, CI and MI levels		64
Blades and Nozzles of the Hot Section of Gas Turbines		66
Blades and Nozzles of Hot Section of Gas Turbines without Core Casting		68
Combustion Chamber and Gas Turbine Liner		70
Electronic Fuel Control Valve (Governor)		72
Reconstruction and Repair Services of Hot Section Parts of Gas Turbine		74
Fixed and Moving Gas Turbine Blade		76
Control and Protection System in Two Models: Ramyar and Ramyar 2		78
Gas Turbine Flowmeters with Accuracy Below One Percent Gas Turbine Flowmeter		80
Fundamental Overhaul of SGT 100 Turbine		82
Repairing the Hot Section Parts of Neopinion and GE-F5 Turbines		84
PT Rotor of Solar Saturn Gas Turbine and the Blades of 4th and 5th Rows of the PT Section of Sulzer Gas Turbine and the Stator Blades of the AC Section of Solar Saturn Turbine		86
Honeycomb Mesh and Seal		88
Ruston TB4000 Gas Turbine Overhaul		90
Combustion Chamber of WERKSPoor W72M Gas Turbine		92
Blades of Cold Section of Gas Turbine (Compressor) and Steam Turbine		94
Shroud Block Segment of Gas Turbine		96
Coreless Blades of the Hot Section of the Gas Turbine		98
Coreless Diaphragm of Gas Turbine		100
Updating DCS Control System and Gas Turbine Protection		102
Reconstruction and Repair of Innercasing, Mixing Chamber and Liner of Gas Turbine V-942 and BBC13D		104
GE Gas Turbine Flow Divider		106
Fuel System of Industrial and Power Plant Turbines		108
Gas Turbine Rotor with RPM (3000-30000) and Power (3-25 MW)		110
Overhaul of Gas Turbines		112
Power Plant Control Cards		114
Major Repairs of Gas Turbine Model DU80L		118
Cold Section Blades of Gas Turbine and Steam Turbine Blades		120
Machining and Production of Gas and Steam Turbine Blades		122
Solar Turbine Control System		124
Ruston TA 1750 Gas Turbine Burner		126
Repair and Reconstruction Services of Gas and Steam Turbine Parts Using the Plasma Transferred Arc Welding (PTAW) Method		128
Testing and Alignment Services of V94.2, GE-F9 and MHI Turbine Fuel Injectors		130
Outer Casing and Stator Casing Parts of Gas Turbines Cast		132
C-Level Overhaul of SGT 100 and SGT 600 Gas Turbines		134
Overhaul, Troubleshooting and Major Repairs of MAN-THM 1304 Gas Turbine		136
Overhaul, Troubleshooting and Major Repairs of SOLAR-TAURUS 70 Gas Turbine		138
160 MW MST-50C Steam Turbine		140
Redesigning and Manufacturing the Blades of the Low-Pressure Section of Steam Turbines		142
Steam Turbine Rim and Blade		144
Complete Package of Single-Stage Impulse Steam Turbines Up to 1.1 MW		146

Repair and Reconstruction of the Integrated Rotor (Forged) of the Steam Turbine		148
Package of Single-stage Impulse Steam Turbines with Power of Less Than 3MW		150
Machining and Production of Various Parts of Water and Steam Turbines and Impeller		152
Online Performance Analysis of Process Turbocompressors of Petrochemical Units		154
Inspection and Failure Analysis of Process Turbocompressors of Petrochemical Units		156
Wind Turbine Cast Iron Parts		158
Wind Turbine Tower		160
Construction of KW 660 Wind Turbine Asynchronous Generator		162
5 kW Vertical Axis Wind Turbine		164
Simulator of Wind Turbine's Behavior		166
2-25 Inch Turbine Gas Meter		168
A Set of Hot Parts and Fixed and Moving Blades of the GT13 Turbine		170
Fixed And Moving Blades of GE-F9 Turbine		172
Frequency Converter for Starting Gas Power Plants (SFC)		174
Reconstruction and Repairs of Hot Section Blades, Combustion Chamber and Turbine Liner		176
Power Plant Air Filter with Nanofiber Technology		178
Industrial Air Filters Containing Media Modified with Polymer Nanofibers		180
Engineering Services for Failure Analysis and Turbine Blade Life Estimation		182
Parts and Overhaul of the Rotor of Steam Turbines with Power of Less than 20 MW		184
Turbine Hot Parts Including		186
Reconstruction and Repair of Hot Turbine Parts		188
APS and HVOF Coating Services for Turbine Parts		190
Assembly of the Rotors of GEF5 and GEF6 Turbines		192
Power Transmission Gearbox from Turbine to Compressor PHILADELPHIA 206		194
Rejuvenation and Repair of Turbine Blades, BLADE CAREER, Hot Section		196
Other Advanced Turbine Parts		198
Determination of Dynamic Parameters of Power Plant Components		200
Twin & Triple Screw Pump Shaft and Mechanical Seal for Turbine Fuel		202
Testing Dynamic Parameters of Power Plant Units		204
Aluminizing by Cementation Pack Method for Turbine Blades		206
Power Plant Heat Recovery Boilers (HRSG) Class E and F Horizontal Type		208
Power Plant Heat Recovery Boilers (HRSG)		210
Class E (Up to 240 TON_HR Capacity) of Horizontal Type		210
Industrial Boilers (SD Type), Package (SC type) and Power Plant Boilers (SR and SN) with Natural Circulation System		212
Combustion System with Burners of WBG0 Power Plant Boilers		214
Designing the Cooling System of the Main and Auxiliary Air Condenser of a Power Plant		216
EXHAUST System of Power Plants with Different Capacities		218

AIR INTAKE System of Power Generation Plants with Different Capacities		220
Designing the Air Cooling System of Power Plant ACC (Air Cooled Condenser)		222
Design, Equipment Supply, Installation, Repair and Maintenance Services Related to Hydroelectric Power Plants on Water Transmission Lines Up to 10 Megawatts		224
Power Plant Auxiliary Boilers		226
with a Capacity of More than 15 Ton/Hr Super Heat Steam		226
Redesigning and Manufacturing Parts of Bypass and Spray Water Valves of Power Plants		228
Water and Energy Resources Management System (Dam and Power Plant)		230

<i>Gas Turbines and Their Parts</i>	○
<i>Steam Turbines and Their Parts</i>	○
<i>Wind Turbines and Their Parts</i>	○
<i>Other Turbine Parts and Related Services</i>	○
<i>Heat Transfer in Power Plants</i>	○

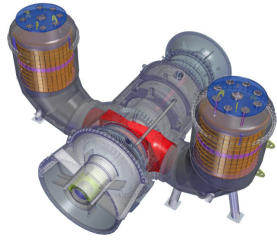
**Application:**

Gas power plants for electricity generation

➤ MGT-70 Series of Gas Turbines

◆ Mapna Turbine Engineering & Manufacturing (TUGA) Co.

www.mapnaturbine.com
**Product Introduction:**

In thermal electricity production industries, reducing the costs of construction, repairs, and operation, as well as increasing the stability and flexibility of thermal machines, are among the basic challenges. Mapna Group, as a leading manufacturer of heavy gas turbines in the Middle East, has included the production of this product with high quality and variety of operation and low maintenance and repair costs in its work plan, and in this regard, has offered gas turbine (3) MGT-70 to the competition market. The project of basic redesign and upgrade of the hot components of the turbine has been implemented for the first time on the (3) MSI-70 turbine with the aim of improving the performance and increasing the availability and reliability of the MGT-70 series turbines. This project has significantly increased the efficiency of the turbine section and some of the results include the following:

- * Aerodynamic optimization of airfoil wings in compressor and turbine
- * Improving the cooling paths and heat transfer inside the airfoil of hot blades
- * Upgrading the components of the secondary air flow system of the turbine in accordance with the improvements made in the design of the blades

Main Export Destinations:

Germany, Italy, Switzerland and UAE

Export History:

Up to 500,000 \$

Founded:

1999

*This product is final B2B equipment.***Technical Specifications:**

Gross output power	185 MW
Shaft speed	3000 rpm
Exhaust gas temperature	544°C
Weight (main engine)	186 tons
Dimensions	3.7 × 3.9 × 10.2 m

Advantages:

- * Reducing unit maintenance costs
- * Can be used in island grids
- * The possibility of entering the combustion compartment for inspection without the need to separate the components of the combustion chamber

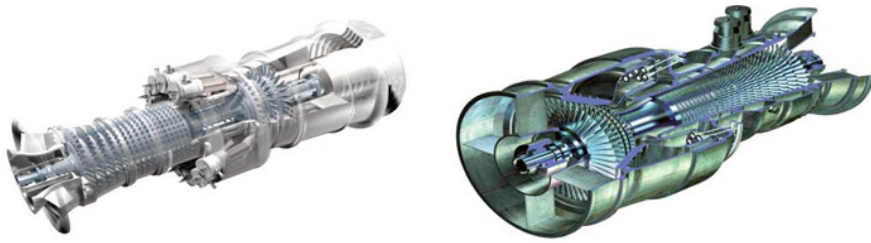

Application:

Used in gas power plant (simple cycle) for electricity regeneration

➤ **Fixed and Moving Blades of MGT-70 Gas Turbine**

MAP2B, MAP2A, MAP2+

◆ **Mapna Turbine Blade Engineering & Manufacturing (PARTO) Co.**

www.mapnablade.com



Product Introduction:

The MGT-70 turbine, as an upgraded version of the V94.2 turbine, has features that have caused changes compared to the original model of this machine. Among the changes, we can mention the improvement of the mechanical design, the improvement of the combustion chamber, the improvement of the hot gas path, the improvement of the turbine cooling system, and the improvement of the aerodynamics of the turbine and compressor blades. The total of these changes has led to an increase in production power from 157 MW to 185 MW, which is an impressive and significant figure, and in addition, it has resulted in a two percent increase in turbine efficiency in the simple cycle.

This turbine was developed based on the Siemens turbine platform by the TUGA company from the Mapna group and is one of the E-class gas turbines in the country. All the fixed and moving blades of this turbine were produced under the license of Siemens, Germany, in the Parto company. This turbine has four rows of fixed and movable blades in the hot section, and the combustion system of the turbine consists of two chambers and has a rated capacity of 162 MW in ISO conditions.

Main Export Destinations:

Turkey

Export History:

Up to 500,000 \$

Founded:

2000

This product is final B2B equipment.

Technical Specifications:

Blade material	Nickel based superalloys
Manufacture technology	Equiaxed

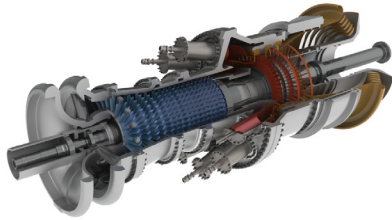
**Application:**

Electricity generation and mechanical propulsion

➤ MGT-40 Gas Turbine**◆ Mapna Turbine Blade Engineering & Manufacturing (PARTO) Co.**www.mapnablade.com**Product Introduction:**

This turbine is reverse engineering of GE-F6 turbine. The turbine is a class E turbine and single shaft, and the ability to transport and install easily and the ability to start quickly are among the advantages of this turbine. This turbine is used as mechanical drive in simple, combined cycles or systems of simultaneous production of electricity and heat. The nominal power capacity of this turbine is 42.2 MW and its real power capacity is 42.01 MW. The main feature of the MGT-40 gas turbine is its high availability, reliability and flexibility, and as a reliable machine in harsh conditions, is a suitable option for sensitive industries such as petrochemicals and refineries. The MGT-40 gas turbine has an axial compressor with 17 rows of fixed and movable blades, one IGV row, two EGV rows and 10 circular combustion chambers.

Main Export Destinations:

Turkey

Export History:

Up to 500,000 \$

Founded:

2000

*This product is final B2B equipment.***Technical Specifications:**

Gross output power	42.2 MW
Gross productivity	%32.2
Shaft speed	5160 rpm
Exhaust gas temperature	°548C

Advantages:

- ※ Ability to start in two modes, ISLAND and DROOP
- ※ Working as an island in combined cycles
- ※ Function as MECHANICAL DRIVE
- ※ Ability to work in unstable networks

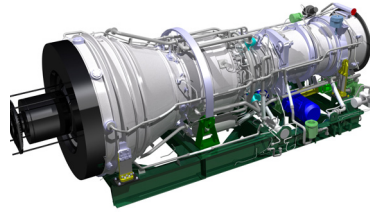

➤ MGT-30 Gas Turbine Series

Turbogenerator and Turbocompressor

◆ Mapna Turbine Engineering & Manufacturing (TUGA) Co.

www.mapnaturbine.com



Product Introduction:

The 25 MW MGT-30 gas turbine is used to produce electric power and mechanical thrust for rotating equipment such as compressors and pumps in various industrial processes. The nominal speed of this turbine in turbocompressor and turbopump units is 5000 rpm. Another type of this turbine, which is designed for electricity generation, has a speed of 3000 revolutions per minute and is used in small and simple combined cycle power plants, including mobile power plants, CHP units, and in various industries such as water desalination.

This gas turbine with 36% efficiency includes two separate Gas Generation sections, including low-pressure and high-pressure compressors, 16 Can Annular combustion chambers, low-pressure and high-pressure turbines, and the Power Turbine section includes a power turbine with rotary and stator blades.

Main Export Destinations:

Germany, Italy, Switzerland and UAE

Export History:

Up to 500,000 \$

Founded:

1999

Application:

Electric power production and mechanical thrust of rotating equipment such as compressors and pumps in various industrial processes

This product is final B2B equipment.

Technical Specifications:

Gross output power	25 MW
Shaft speed	3500-5000-5250 rpm
Frequency	50 Hz
Weight (main engine)	14.2, 15.1 tons
Dimensions	2.5 × 2.3 × 6.3, 2.5 × 2.4 × 6.3 m

Advantages:

- ※ Change in the liner cover and redesign of the cooling system of areas prone to burns
- ※ Improvement of bushing surface roughness
- ※ Use of coating in the blade root of the 3rd and 4th rows of LPC, as well as changing the control process and changing the assembly method of these blades

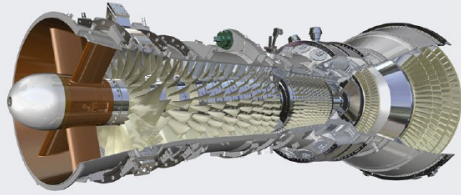

► MGT-30 Mobile Turbine Series

4 Chassis

◆ Mapna Turbine Engineering & Manufacturing (TUGA) Co.

www.mapnaturbine.com



Product Introduction:

This power plant consists of a group of four chassis that contain all the electrical power generation equipment with a maximum capacity of 26 megawatts. This power plant is designed with the aim of placing the most equipment in the least possible space on the chassis. Installing the equipment on these chassis brings the advantage of fast mobility of this power plant by land and sea. The main part of the equipment installation and testing steps are done before sending to the site and inside the factory, so that after sending to the site, only a small part of the equipment installation and network connection steps remains, which takes less than 1 month to be done. MGT-30 turbine is used in this power plant, which can be operated with two fuels, gas and diesel, and can be connected to the grid in a short period of time.

Main Export Destinations:

Germany, Italy, Switzerland and UAE

Export History:

Up to 500,000 \$

Founded:

1999

Application:

- ✧ Compensating for the lack of electricity production caused by the main power plants being out of service due to accidents or major repairs.
- ✧ Provision of electrical energy during unexpected and unpredictable events
- ✧ Seasonal peaks and voltage and frequency stabilization of local networks
- ✧ Supply of electricity needed for industrial and mining projects (development of oil and gas fields, petrochemicals and mines, etc.)

This product is final B2B equipment.

Technical Specifications:

	Gas fuel	Oil fuel
Gross output power (MW)	25	23.8
Frequency (Hz)	50	50
Gross efficiency (%)	35.9	35.4

Advantages:

- ✧ Quick and easy installation
- ✧ Fast and easy displacement
- ✧ Power generation in a short time

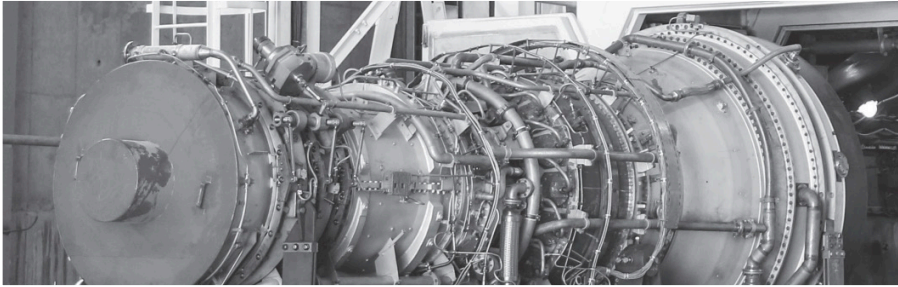

➤ Fixed and Moving Blades of MGT-30 Turbine

◆ **Mapna Turbine Blade Engineering & Manufacturing (PARTO) Co.**
www.mapnablade.com



Product Introduction:

ZORYA turbines are used in gas pressure boosting facilities as the primary driver after being coupled to the gas compressor to increase the gas pressure. A turbocompressor unit installed in gas pressure boosting stations includes one or more types of turbines of this type. The fixed and moving blades of this turbine are produced in the company. This machine has two main parts: Compressor turbine (GG) and Power transmission turbine (PT). Moreover, the combustion system of this turbine is of CAN ANNULAR type with a nominal capacity of 26 MW in ISO conditions. The Parto company produces all the fixed and moving blades of the hot section of this turbine.

This product is final B2B equipment.

Technical Specifications:

- * **Blade material:** Nickel based superalloys
- * **Manufacture technology:** Equiaxed

Main Export Destinations:

Turkey

Export History:

Up to 500,000 \$

Founded:

2000

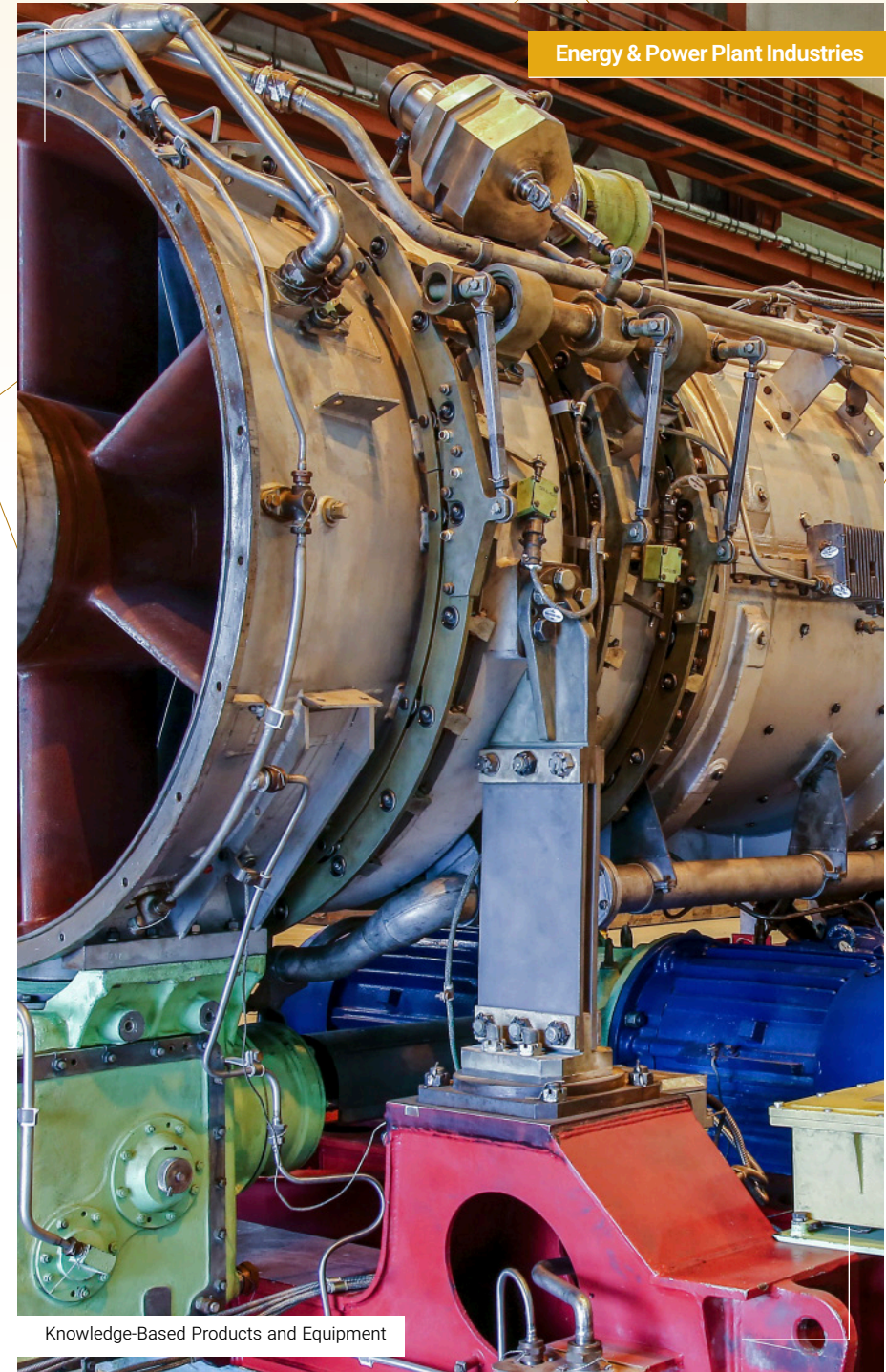

Knowledge-Based Products and Equipment



Application:

Starting up the rotor of gas turbines Uniform cooling of the rotor when turning off the turbine

➤ **Turning Gear of MGT-75 Gas Turbine**

◆ Durali System Design & Automation (DSDA) Co.

www.dsdaco.com



Product Introduction:

Before starting the gas turbine, its rotational speed should be brought to a certain limit where the burners are turned on, so that they can slowly heat the turbine by heating the compressed air coming from the compressor. This rotor is started by a device called Turning Gear. Turning gears are designed and manufactured in 3 ways according to the speed and torque: Pelton turbine mechanism, torque converter or pinion and gear wheel. Pelton turbine mechanism is outdated and is not used in modern power plants.

Also, due to the heavy mass of the rotor of the turbines, special attention should be paid to the issue of uniform thermal conduction in its longitudinal and radial directions, because the non-uniformity in the cooling of the rotor causes thermal stresses and, as a result, bending and changing its shape. To prevent this, when the rotational speed of the rotor reaches a certain number, the turning gear is engaged and rotates the rotor for a certain period of time (6-8 hours) to cool down evenly.

Founded:

2016

This product is final B2B equipment.

Technical Specifications:

Torque	120 N.m
Rotational speed	1500 rpm
Gear design	KeySoft software
Main pinion material and idler gear	VCN 150

Advantages:

Using pinion and gear mechanism



➤ MGT-75 Gas Turbine Gas Skid Design

◆ Durali System Design & Automation (DSDA) Co.

www.dsdaco.com



Product Introduction:

Gas turbines are ideally designed based on the Brayton cycle. In this cycle, in order to increase the enthalpy of compressed gas in the compressor section, gas combustion is used in the combustion chamber. This gas will be supplied to the burners through the gas skid for each turbine. The combustion chamber of MGT-75 gas turbine is Can Annular. This skid provides the gas required for turbine start and warm-up and full load. In this skid, the temperature, pressure and flow rate of the gas entering the skid after passing through the filter must be measured; Then the gas passes through a shut-off control valve and enters the path of three output control valves: a pilot valve, main valve 1 and main valve 2. All the control valves used are globe-type hydraulic actuators.

Application:

Supplying gas required for turbine start, warm-up and full load in power plants

This product is final B2B equipment.

International Standards or Permissions:

ECI 60534-2

Founded:

2016





➤ A Set of V94.2 Gas Turbine Hot Parts

Fixed and Movable Blades and Swirler

◆ Mapna Turbine Blade Engineering & Manufacturing (PARTO) Co.

www.mapnablade.com



Product Introduction:

The V94.2 gas turbine is one of the heavy class gas turbines used in thermal power plants to drive generators. This turbine, which fits in the form of single-axis turbines, can also be used in combined cycles, and for this reason, is of interest to power plant investors. A gas turbine has one or more rows of fixed and moving blades in the compressor and turbine parts (compressor turbine or power turbine). Fixed and moving blades in different gas turbines have different designs.

Application:

- ※ **Fixed blade:** Speeding up the gases entering the turbine
- ※ **Moving blades:** Converting the internal energy of incoming gases into mechanical energy

This product is final B2B equipment.

International Standards or Permissions:

- ISO 9001, 14001, 27001, 50001 ※
- OHSAS 18001 ※

Founded:

2000

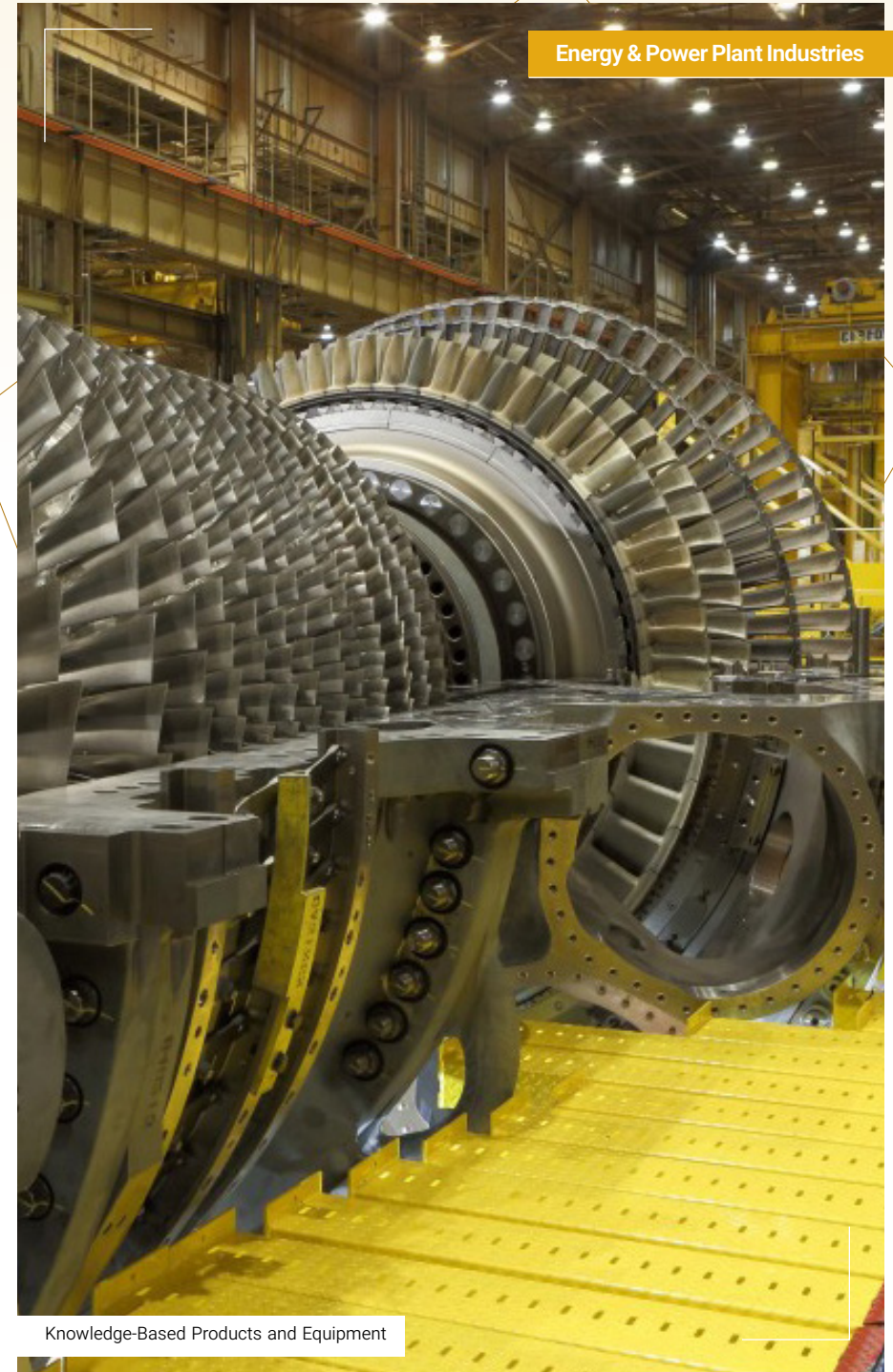

Knowledge-Based Products and Equipment



➤ Construction of Gas Turbine Combustion Chamber

Mixing Chamber and Chamber Shell

◆ Sepahan Mapna Engineering & Equipment Manufacturing Co.

www.mapnasts.ir



Product Introduction:

The combustion chamber of the gas turbine is located between the compressor and the turbine and is generally known as an engine for burning fuel and increasing the temperature of the incoming air. Combustion takes place at almost a constant pressure. All gas turbine combustion chambers work with a specific function and basis. They increase the temperature of high pressure gases. The combustion chamber of gas turbines uses a small percentage (approximately 10%) of the incoming air for combustion. Most of the incoming air is used for cooling and mixing. New combustion chambers use steam circulation for cooling.

Application:

Generating the necessary power to drive the gas turbine

This product is final B2B equipment.

Technical Specifications:

Material: 625 nickel based superalloys

Founded:

1996

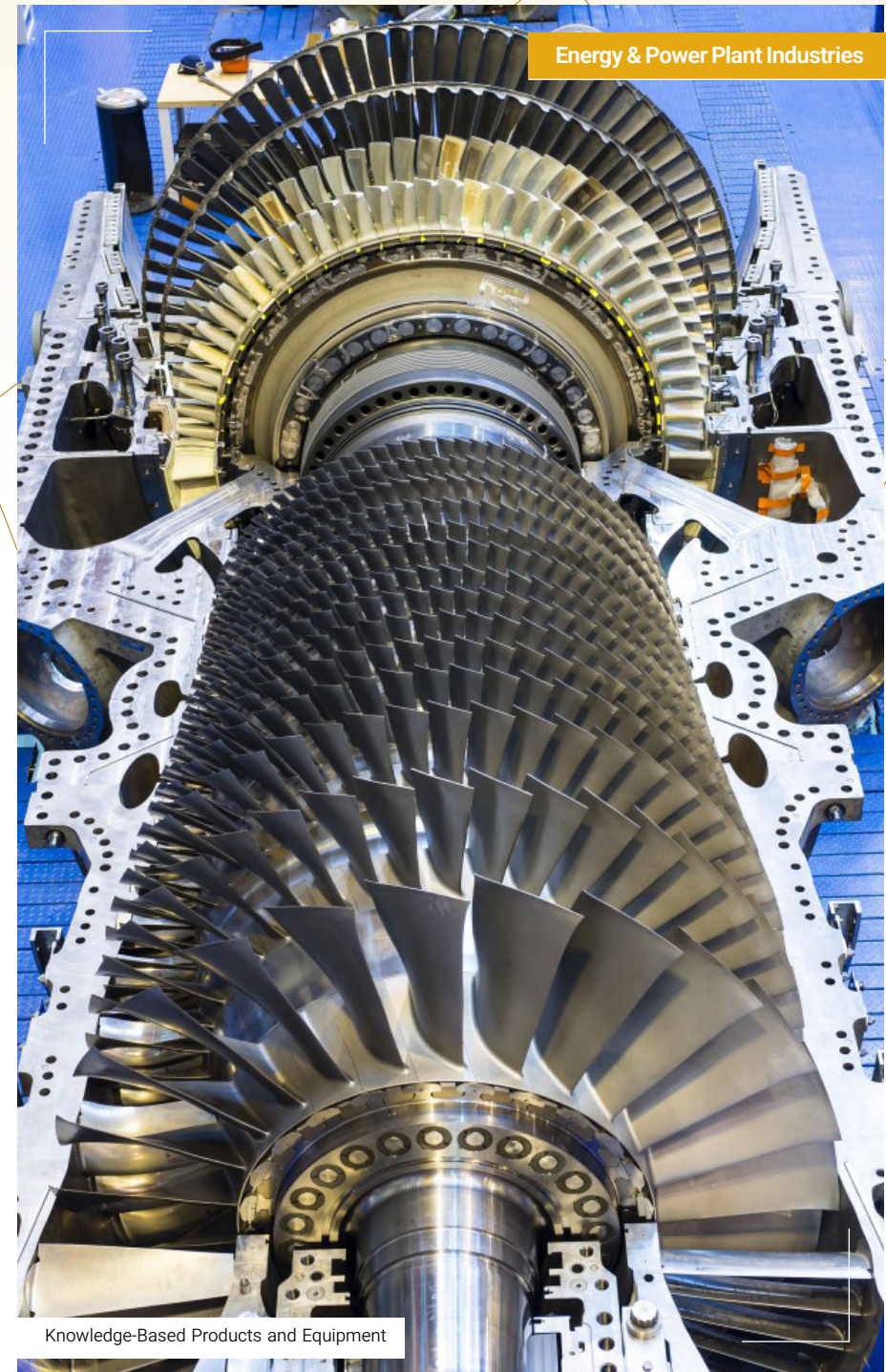

Energy & Power Plant Industries

Knowledge-Based Products and Equipment

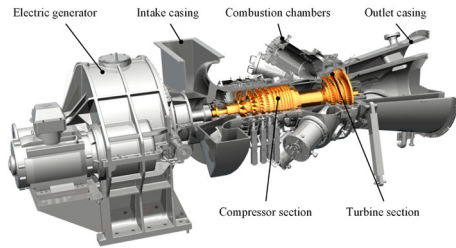

Construction of the Hot Gas Inner Casing of the Gas Turbine

Hot Gas Inner Casting

◆ Sepahan Mapna Engineering & Equipment Manufacturing Co.

www.mapnasts.ir



Product Introduction:

The inner shell in a gas turbine has the task of directing hot gases (more than 1000 degrees Celsius) from the combustion chamber to the inlet and turbine blades; On the other hand, in the external part, cold compressed air flows in the form of a channel perpendicular to the hot incoming air flow in order to cool the turbine shaft and accessories.

Application:

Directing hot gases (more than 1000 degrees Celsius) from the combustion chamber to the inlet and turbine blades

This product is final B2B equipment.

Technical Specifications:

Material: 617 nickel based superalloys

Founded:

1996



Knowledge-Based Products and Equipment

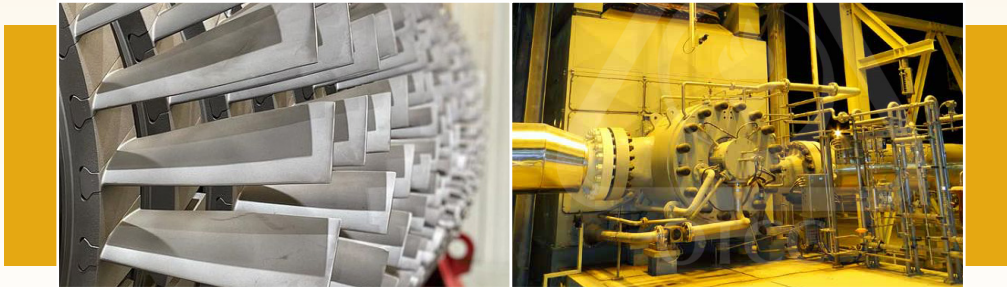

➤ 25 MW Gas Turbine Package

◆ Middle East Gas Turbines (MIGT) Co.

www.otcc.ir



Product Introduction:

The national turbine is a two-shaft natural gas turbine. This turbine was initially designed for loading from compressors and pipelines, and due to its strong design and optimal economic consumption, it was also adapted to generate power. The IGT25 turbine is delivered with low pollution and according to the standard. With the simultaneous combination of pollution and low fuel consumption, it can be claimed that the national turbine is one of the most compatible turbines with the environment in the group of turbines of the same class in terms of power. The national turbine has a long lifespan in all imaginable working conditions. This gas turbine has a ten-stage axial air compressor, which is connected to a high-pressure two-stage turbine with a shaft. The low-pressure two-stage turbine is located after the high-pressure turbine and produces the output power of the engine.

Founded:

2007

Application:

- ※ Forming an important part of the equipment needed in oil industries
- ※ Pressure increase in gas transmission sites
- ※ Electricity generation in local power plants

This product is final B2B equipment.

Technical Specifications:

Nominal power	25 mW (Upgradable up to 30 mW)
Gas generator rate	9800 rpm
Power turbine rate	7700 rpm

Advantages:

- ※ Low fuel consumption and high efficiency in the long term
- ※ Low pollution
- ※ Very high compatibility with the environment
- ※ Low life cycle cost
- ※ Ability to use a variety of fuel in a wide range
- ※ Ability to use liquid and gas fuel



► PT Rotor of the GEC Gas Turbine

◆ Turbine Machine Co.

www.turbinemachine.com



Product Introduction:

The gas turbine rotor consists of two parts: the PT rotor and the GG rotor of the gas turbine. The GG rotor of gas turbines has the task of supplying and compressing the air required by the turbine for combustion and cooling the gas resulting from combustion, in the combustion chamber (for example, the SGT600 turbine, pressure of about 15 bar and a flow rate of about 80 cubic meters per minute in working rate of 10500 rpm). The PT rotor of gas turbines does the task of converting the kinetic energy of gas caused by combustion into mechanical energy and moving the gas transfer compressor or generator connected to the PT rotor. These rotors consist of several disks connected to each other and the main shaft that is connected to the disk.

Main Export Destinations:

Syria

Export History:

Up to 500,000 \$

Founded:

2002

Application:

Converting the kinetic energy of the combustion gas into mechanical energy

This product is final B2B equipment.

Technical Specifications:

The material of the disks	Superalloy
Geometrical tolerance of discs	5 μ



Application:

- * **Turbodiag product:** Condition monitoring and troubleshooting of gas turbines and other rotating machines in the oil and gas industry
- * **Turboflex product:** Optimization of turbine performance in the gas turbine control system
- * **Turboram product:** It is used in all centers that use gas turbines.

➤ **Design and Engineering of the IGT25 Gas Turbine**

🏠 **Turbotec Co.**

www.turbotec-co.com



Product Introduction:

Offering design and engineering services in the after-sales service sector of gas turbines includes the following three softwares:

- * **Turbodiag product:** By collecting data from the vibration and performance sensors of the gas turbine online and performing various analyses, it examines the health status of the turbine in both vibration and performance domains online. By analyzing the results of the analysis, the turbine is examined and the possible defects of the turbine are detected and displayed on the HMI screen for the user's information.
- * **Turboflex product:** By using smart optimization algorithms and a precise gas turbine model in the control system, online and in real time, based on the functional conditions and life, efficiency and power, it determines the optimal amount of control actuators.
- * **Turboram product:** It is an intelligent tool for optimal repair and upgrade decisions, which has the two functions of increasing reparability and reliability of the system.

Founded:

2010

This product is final B2B service.

Advantages:

Turbodiag product	<ul style="list-style-type: none"> * Vibration monitoring with data collection and online monitoring and troubleshooting using all vibration analysis. * Storage of the raw vibration signal before and after the occurrence of the problem (for example, passing the alarm of sudden change of vibrations) in a long period of time.
Turboflex product	Development of an accurate model of turbine behavior and determination of optimal control theory
Turboram product	<ul style="list-style-type: none"> * Identification of sensitive spots and critical equipment * Providing solutions to improve reliability and reparability * Providing optimal maintenance and repairs program

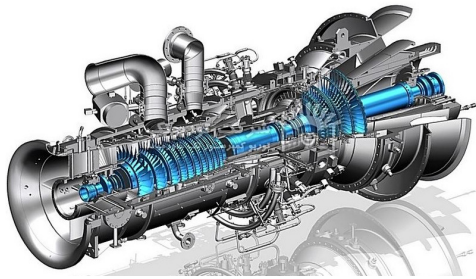

► **Design, Engineering and Basic Upgrading of IGT25 Gas Turbine Along with its Advanced Equipment**

Including Compressor, Combustion Chamber, Blade, Rotor and Control System Hardware and Software.

◆ **Turbotec Co.**

www.turbotec-co.com



Product Introduction:

A gas turbine is a rotating machine that works based on the energy of gases from combustion. Each gas turbine includes a compressor to compress air, a combustion chamber to mix air with fuel and ignite it, and a turbine to convert the energy of hot and compressed gases into mechanical energy. Part of the mechanical energy produced in the turbine is used to turn the compressor of the turbine itself, and the rest of the energy, depending on the function of the gas turbine, may turn the electricity generator (turbogenerator), or move the compressor of gas stations (turbocompressor) or create propulsion in airplanes (turbojet). All turbines work based on the principle that air is drawn and compressed into a tube-like container, mixed with fuel and burned, and exits at a high speed.

Founded:
2010

Application:

Torque production and power production in the petrochemical industry

This product is final B2B service.

Technical Specifications:

Mechanical drive	25.40 mW
Shaft efficiency	33.5 %
Heat range	10528 kJ / kW.h
Turbine rate	7700 rpm

Advantages:

- * Low depreciation
- * Low cost of repairs

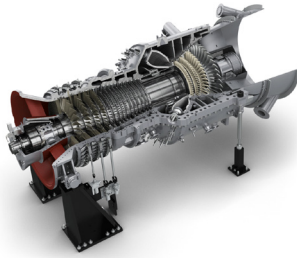
**Application:**

Oil, gas and petrochemical refineries and gas transmission lines

► Design of IGT25 Gas Turbine Plant to Operate in Petrochemical Combined Cycle Mode

► Turbotec Co.

www.turbotec-co.com

**Product Introduction:**

Combined cycle includes gas turbine and boiler. In this cycle, by using the recovery boiler, the heat in the exhaust gases from the gas turbines is used to produce steam. If the gas turbine is not a combined cycle, its exhaust gases, which can have a temperature of up to 600 degrees Celsius, are directly injected into the air and the remaining energy is wasted. While in the combined cycle, this energy is used and the boiler produces steam without the need for fuel. Therefore, by using this method, the efficiency of the cycle increases. The heat recovery boiler is the main heat recovery equipment in a combined cycle. In most power plants, the recovery boiler uses the heat of exhaust gases from the gas turbine to produce steam with high pressure and temperature. The energy transferred to the recovery boiler by the gas turbine is usually equal to the rated output of the gas turbine in the design conditions.

Founded:

2010

This product is final B2B service.

Advantages:

Increasing the cycle efficiency

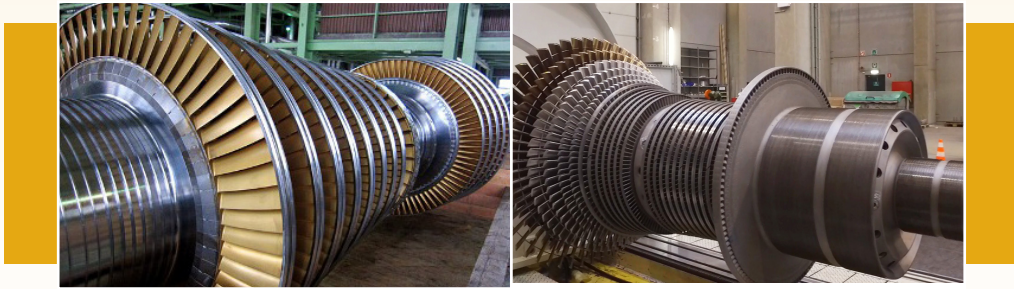

➤ **Design, Engineering and Reconstruction of Gas Turbine Hot Parts (Blade and Combustion Chamber)**
Remaining Useful Life Estimation, Rejuvenation and Repair

◆ **Turbotec Co.**

www.turbotec-co.com



Product Introduction:

When a blade or combustion chamber of a gas turbine works at high temperature, it can suffer from various damages. These damages may be physical or related to the microstructure. Therefore, over time, the piece loses its initial efficiency. The gas turbine parts are repaired in different stages, during which the metallurgical and dimensional properties of the parts are restored. In general, the fixed and moving components of a gas turbine are subject to these damages:

- ※ **External physical damage:** External damage includes fatigue cracks, surface oxidation and corrosion, FOD and abrasion.
- ※ **Internal microstructural damage:** Internal microstructural damage also includes the dissolution of carbides in the grain boundary, change in phase, change in grain size and the structure of nickel-based superalloy, which can be solved by rejuvenation heat treatment.

Founded:

2010

This product is final B2B service.

Application:

Cleaning and removing the coating	Cleaning is usually done before the inspection and before and after the repair and reconstruction operation by two chemical and mechanical methods.
Life estimation	Estimating and increasing the life of gas turbine parts that are made of super alloy due to critical working conditions of high temperature and stress is very important, especially in the case that the turbine is opened and taken apart for periodic maintenance.
Rejuvenation heat treatment	By working the piece at high temperature, the dimensions and shapes of Γ' deposits change and also a brittle layer of carbides is created along the grain boundary, which will reduce the toughness and creep resistance. By increasing the temperature up to the dissolution temperature of the Γ' phase, these deposits return to their original state, and rapid cooling prevents the formation of Γ' deposits.
Reconstruction by welding	Welding is used to repair cracks.
Reconstruction by brazing	The advanced brazing method provides the possibility of rebuilding parts of the turbine that are not possible according to the usual methods.
Coating	If needed, the recoating of the blades should be done using hvof or aps processes.

**Application:**

Power plant industries

➤ Cold Section Spare Parts of Gas Turbines

🏠 TurbineMachine M.E.Parts Supplier Co.

www.turbinemachineparts.com
**Product Introduction:**

This company is in charge of re-designing, manufacturing and delivering hot and cold parts of Ruston, Solar Saturn, Solar Centar, Sulzer, Dresser Rand, Rolls Royce and Tida gas turbines at the request of Khavar Mianeh Machine Turbine Company. Easing its efficiency, to the extent that the smallest error in the construction or design of these parts causes the loss of turbine efficiency or brings the turbine operating conditions closer to the surge and instability state. Considering the high speed of small turbines, the smallest contact resulting from interference of parts due to surge will cause irreparable damage to the turbine.

Founded:

2011

*This product is final B2B equipment.***Technical Specifications:**

- * CMM and production of point clouds and 3D map production.
- * Material selection through the material analysis of the depreciated sample.
- * Preparation of raw forged material; In order to make blades, first, their forged materials are prepared from heat-resistant materials according to the working temperature. Forged material is used to make moving blades; Because in forging, alignment of molecules and strength are higher.
- * Converting 3D design to GCODE for sending to CNC machines and blade machining
- * Final quality control of blades



➤ 2 KW Gas Micro-Turbine Simultaneous Generator of Electricity and Heat

◆ S.M.D Middle East Co.

www.microturbine.ir



Product Introduction:

The need for electric energy in today's society and according to the types of uses (domestic, commercial, industrial and agricultural) is a growing need. In order to provide energy to consumption points, electric energy must be produced in power plants and delivered to the consumer through transmission and super distribution lines, But if electrical energy can be produced at the place of consumption to supply a part of the network load, considerable savings will be made in all of the mentioned sectors. Microturbines have a rotation speed between 60,000 and 90,000 rpm, which cannot be compared with other power generation equipment.

Founded:
2015

Application:

Domestic heating and air conditioning, industrial, commercial, baking industries, greenhouse, etc

This product is final B2B equipment.

Technical Specifications:

Thermal power	24-32 kW
Electrical power	1-2 kWh
Electrical efficiency	%10
Simultaneous efficiency of electricity and heat	%98
Fuel type	Town gas

Advantages:

- * Correcting consumption during peak electricity consumption hours
- * Cheap energy

International Standards or Permissions:

BS EN 50465-2015



➤ LTE and RI Overhaul and Repairs of Gas Turbines in HGPI, CI and MI levels

◆ Alborz Turbine Mapna Engineering & Support Co.

www.alborzturbine.com



Product Introduction:

The gas turbine needs a periodical inspection in the time intervals determined by the manufacturer, because the turbine components are subject to various metallurgical damages such as creep, fatigue, corrosion and abrasion during operation. The most important effects of the mentioned damages is the reduction of the life of the parts. For example, the expected life of a combined cycle power plant is 30 to 40 years, but the design life of a gas turbine is 10 to 15 years (3000 starts or 100 to 120 KEOH). Meanwhile, the life of the components of the hot section is also shorter. The operating life of a turbine is influenced by the type and quality of fuel, turbine loading cycles, the starting frequency and operating environment. For the purpose of periodic inspection, the gas turbine is examined in the intervals determined by the component manufacturer in three levels: Combustion Inspection, Hot Gas Path Inspection, and the entire turbine (Major Inspection).

Application:

Periodic inspection of power plant equipment

This product is final B2B service.

Technical Specifications:

Every 8000 hours, the combustion chamber part must be inspected due to being under the most severe thermal stresses. This time interval for the hot section part (combustion chamber and turbine rotor) is every 16000 hours and for the whole turbine every 32000 hours. It is worth mentioning that these numbers are approximate. For the V94.2 turbine these numbers are 24000 ,8000 and 66000 hours respectively. Also, according to the formula provided by the manufacturer to the operator, these times can change based on the turbine loading conditions and the duration of the turning gear. After about 3 or 4 times Major Inspection or in case of an accident, the turbine rotor undergoes RI.

The RI process includes the following steps:

- * Examining the condition of the unit and collecting the necessary information (vibrations and production power, etc.) before removing the turbine from the operating network.
- * Isolate the turbine from the fittings
- * Checking turbine instruments and their calibration
- * Dismantling the rotor at the employer's site and transferring it to the operational workshop
- * Dismantling the rotor into small parts
- * Inspection of parts and examination of the condition of parts in order to generalize the use of parts, necessary repairs or replacement with new parts.
- * Disc and rotor assembly
- * Disc and rotor balance
- * Transferring and placing in the main position on the employer's site



► Blades and Nozzles of the Hot Section of Gas Turbines with Core Casting and Produced Using the Forging Process

◆ MavadKaran Engineering Co.

www.mavadkaran.com



Product Introduction:

Fixed and movable blades are the most important parts of turbines, which have a complex geometry in terms of shape and dimensions. Shroud, airfoil, platform, root and fillets are important parts of a turbine blade. In the turbine, due to the high temperature and speed of the equipment, high stresses are applied to the parts and blades. The blades used in the hot areas of the gas turbine can be divided into three main categories in terms of the manufacturing process. The first category are blades that do not have an internal cooling system and are produced using the forging process. The second category is precision casting blades, which respectively have a cooling system, and therefore core is used in their production process, and the third category is precision casting blades that do not have a cooling system.

Main Export Destinations:

Italy, Turkey

Export History:

Between 500,000 - 1,000,000 \$

Founded:

1996

Application:

Converting kinetic energy of hot fluid into rotational energy

This product is final B2B equipment.

Technical Specifications:

Blade production steps:

- * Performing reverse engineering and modeling process
- * Performing the process of wax injection, coring and molding
- * Precision casting, dissolution heat treatment, machining (creep grinding, flat stone, wirecut)
- * Hardfacing welding
- * Assembling the seal plate next to the root by brazing method
- * Aging heat treatment
- * Applying SermaLoy J coating or other protective coatings



➤ Blades and Nozzles of Hot Section of Gas Turbines without Core Casting

◆ MavadKaran Engineering Co.

www.mavadkaran.com



Product Introduction:

The production process of the blades and nozzles of the hot section of gas turbines, which do not use core in their casting, is exactly the same as the process described in the product with core casting (Previous Page), with the difference that in this case, there is no need to use ceramic cores to create cooling paths in the final product.

Application:

Converting kinetic energy of hot fluid into rotational energy

This product is final B2B equipment.

Main Export Destinations:

Italy, Turkey

Export History:

Between 500,000 - 1,000,000 \$

Founded:

1996

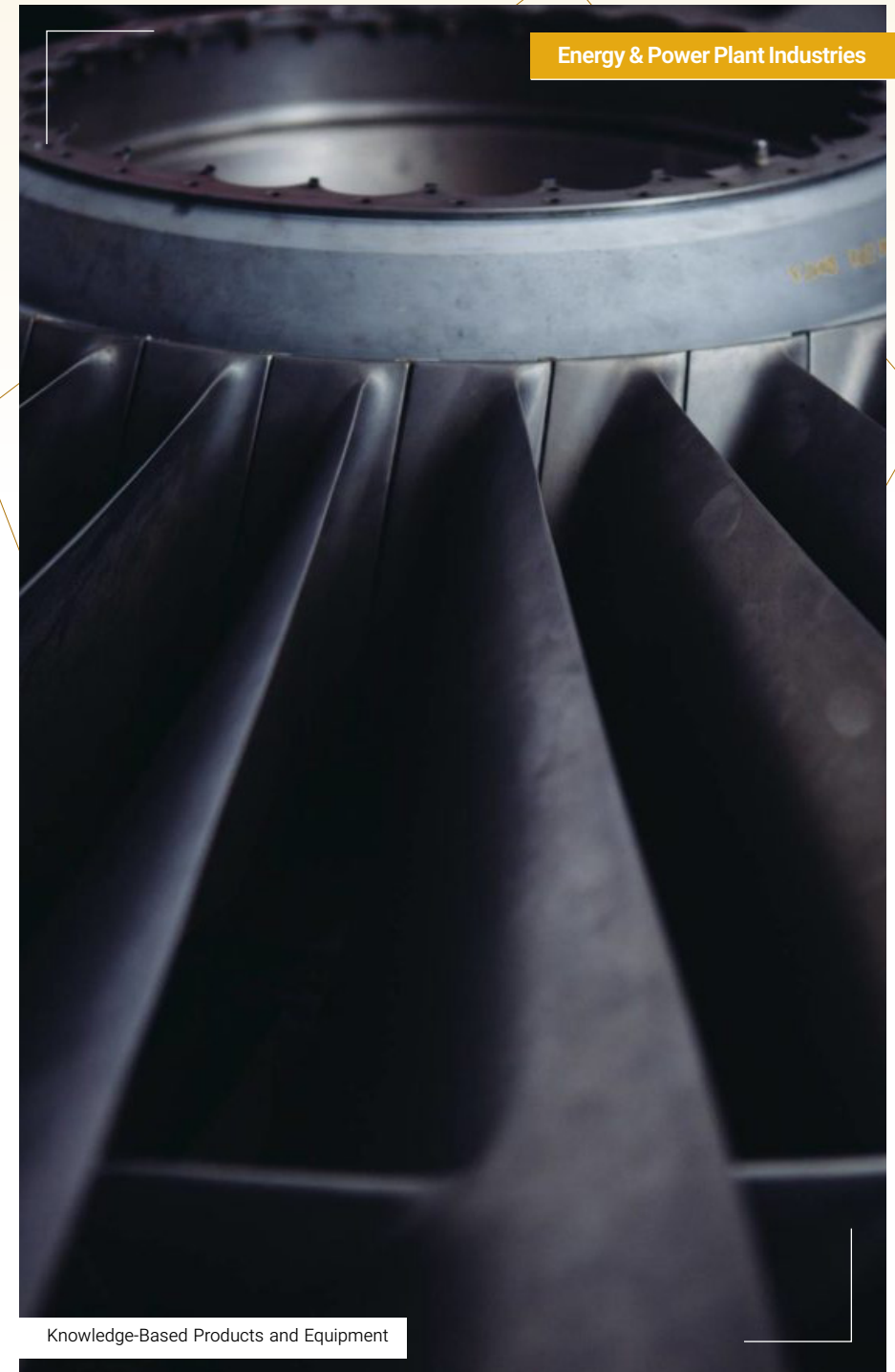

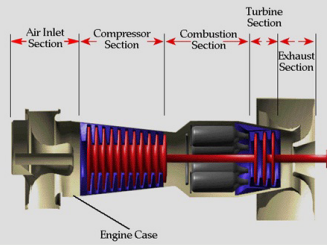

Application:

An engine for burning fuel and increasing the temperature of the incoming air in gas turbines

➤ **Combustion Chamber and Gas Turbine Liner**

◆ MavadKaran Engineering Co.

www.mavadkaran.com



Product Introduction:

The combustion chamber of the gas turbine is located between the compressor and the turbine and is generally known as an engine for burning fuel and increasing the temperature of the incoming air. Combustion is done almost at a constant pressure and all gas turbine combustion chambers work with a specific function and basis. They increase the temperature of high pressure gases. The combustion chamber of gas turbines uses a small percentage (approximately 10%) of the incoming air for combustion, and most of the incoming air will be used for cooling and mixing. New combustion chambers use steam circulation for cooling.

Main Export Destinations:

Italy, Turkey

Export History:

Between 500,000 - 1,000,000 \$

Founded:

1996

This product is final B2B equipment.

Technical Specifications:

Coating	Overlay
	Metal
	Ceramic Hardfacing
Material	HASTELLOY-X nickel-based superalloys
	NIMONIC263
	NIMONIC75

Advantages:

High service temperature



➤ Electronic Fuel Control Valve (Governor) for Gas Turbines Below 15 MW

◆ Control Pooyan Co.

www.cpec.ir



Product Introduction:

Governor, in simple words, is a device that controls the speed or another parameter in the prime mover of a system. The prime movers are rotating machines that get their power from another input source of energy such as steam or water. In its most common form, the governor controls the speed of the prime mover by changing the amount of this input energy flow.

The two main components of governor systems are: the speed sensor and the part that controls the energy input valve. In the governor, the signal from the sensed speed is compared with a reference speed signal and an error signal is made which will be used to control the speed of the prime mover. In general, any process that helps control the output of a prime mover (such as gas, steam and diesel engines or gas turbines) can be called a governor. Apart from automatic speed control, the governor can also control other parameters, for example, in a pump, the governor can control the output pressure, so that regardless of the amount of discharge, the pressure remains constant.

Founded:

2005

Application:

Turbine speed controller in various applications such as turbo pump, turbo generator and turbo compressor.

This product is final B2B equipment.

Technical Specifications:

Position control accuracy	Less than %0.05 in the total range
Full opening and closing course	Less than 250 milliseconds
Material	Super alloy Inconel 625 and Inconel 718

Advantages:

- * High position measurement accuracy by eliminating backlash
- * Control with different methods (remote control, gas mass flow control (energy), position control)
- * No need for maintenance and repair due to the use of BLDC motor

International Standards or Permissions:

- * ANSI B16,10
- * API 6D
- * Eu-Type Examination Certificate
- * ISA 75,01

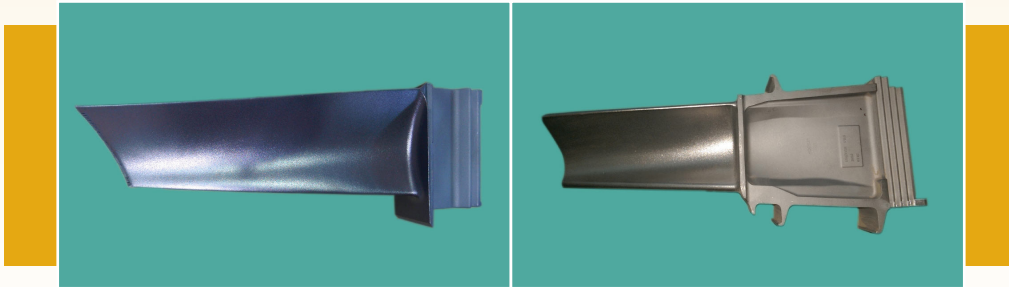

➤ Reconstruction and Repair Services of Hot Section Parts of Gas Turbine by Welding and Recoating

◆ [Shahriar Turbine Components Co.](http://www.sh-turbine.com)

www.sh-turbine.com



Product Introduction:

Due to being placed in the combustion chamber of gas turbines, this part is included in the classification of hot parts. Due to very specific working conditions due to high temperature and wear and also mechanical stresses on this part, the material, geometry and coating of these blades have a special and complex technology. The geometry and dimensions of these blades are very accurate and the specific curvature of each blade is determined by complex fluid and heat transfer calculations.

Founded:
2000

Application:

Extracting thermal energy in the combustion chamber and transferring it to the shaft in the turbine

This product is final B2B service.

Technical Specifications:

Blade material	High temperature nickel superalloys
Coating on blade	<ul style="list-style-type: none"> ※ Mrcralloy coatings ※ Ceramic coatings

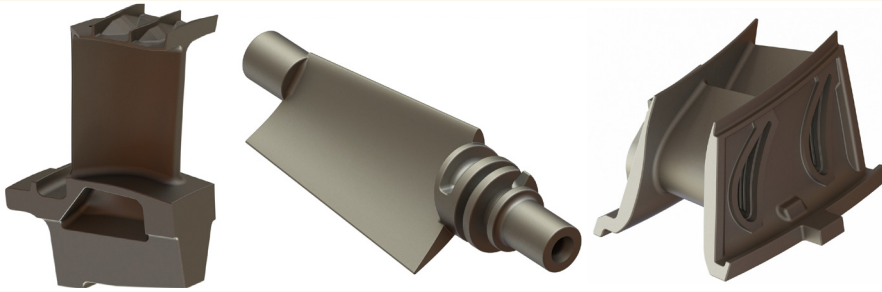

- **Fixed and Moving Gas Turbine Blades** | Including (IGT25-TB1, IGT25-TB2, IGT25-TB3, IGT25-TB4, IGT25-TV1, IGT25-TV2, IGT25-TV3, IGT25-TV4, GEF5-TV1, GEF5-TV2, V93.0-TB1, V93.0-TB2, V93.0-TV1, V93.0-TV2 and V93.0-TV3)

◆ Pars Investment Casting Co.

www.parscasting.com



Product Introduction:

The basis of the operation of gas turbines is to receive and use the energy released from the combustion of gas caused by the combination of compressed air and fuel, and this whole process takes place in three separate phases but continuously inside each gas turbine. joins the event; Therefore, each gas turbine consists of three independent alternating parts, which include the air compressor unit (Gas Generator), the combustion chamber unit (Combustion chamber) and finally the power turbine unit (Power Turbine). The most important part in gas turbines, which has the task of converting thermal energy into mechanical energy, is its blades. In a gas turbine, a group of blades are fixed and another row, based on the design of the turbine, are rotating along with the rotating shaft, which are called fixed blades and moving blades, respectively. The offered products are in fact the fixed and moving blades cast in the gas turbine, which are designed and produced based on the precision casting process.

Main Export Destinations:

England

Export History:

Up to 500,000 \$

Founded:

2009

Application:

- ※ Moving large pumps inside oil and gas pipelines
- ※ Providing the energy required by factories and special areas apart from the network
- ※ Power generation of nationwide networks in the electricity industry

This product is final B2B equipment.

Technical Specifications:

Alloy	792IN nickel-based super alloy Nickel-based super alloy made of NI939
Input temperature to the blade	From about 800 to 1215 degrees Celsius
Periodic visit	From 10,000 hours

Advantages:

The ability to withstand severe mechanical and thermal stresses due to the unique alloy



➤ Control and Protection System in Two Models: Turbine (Ramyar) and Turbo Pumps and Oil and Gas Compressors (Ramyar 2)

◆ Ahar Power Station Services Co.

www.aharco.com



Product Introduction:

Turbine control system (Ramyar): This product is a control system for super heavy power plant turbines. Ramyar includes all the processes of a gas or steam turbine, such as control, protection, monitoring of all processes, monitoring and application of operator commands. This system is designed for high capacity turbines (more than 4 MW). Ramyar can be installed on any type of turbine regardless of the manufacturer's type and brand.

The control and protection system of oil and gas turbo pumps and compressors (Ramyar 2): The control system of two-shaft turbines with the application of generating torque for turbo pumps and turbo compressors. This type of turbine, in spite of single shaft turbines, is designed to operate at different speeds, and therefore, due to the speed change and also the existence of two parts of the turbine, it has a much more complicated control.

Founded:

2006

Application:

Updating the control systems of old turbines (Retrofit) and also installing them on new turbines in the gas, oil, petrochemical, etc., industries

This product is final B2B equipment.

Technical Specifications:

- * The possibility of installation on all types of turbines with different types
- * Monitoring system design
- * Hardware & Software Diagnostics
- * Main control and protection system of S7-400 family
- * Local and remote monitoring

Advantages:

- * Load control algorithm
- * Intelligent flame detection
- * Starting the turbine with the lowest temperature stress

International Standards or Permissions:

- * IEC 61511
- * IEC 61508
- * IEEE 518
- * ISA 101
- * ISA 18.2
- * IEC 61355
- * IEC 60947

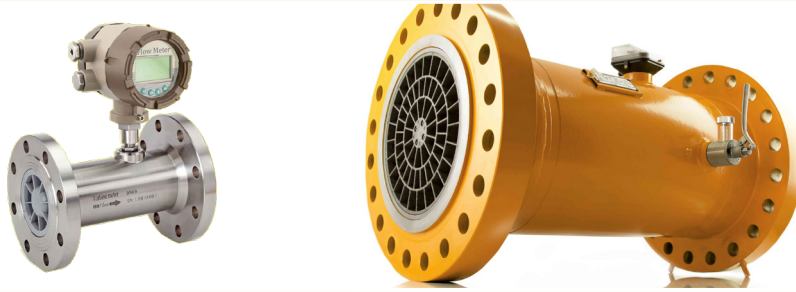

➤ Gas Turbine Flowmeters with Accuracy Below One Percent

Gas Turbine Flowmeter

◆ Delta Gas Mobin Group

www.delta-gas.com



Product Introduction:

This product has three precise main parts, which include the body, rotating rotor inside the body, and the transmission and index (or indicator) set. The body of these meters is manufactured and tested according to EN12261 and 102-IN-IGS standards. Due to the very high sensitivity of this product, special arrangements have been made in the standards and test methods, in which special materials must be used in the first part, i.e. the body, and precise dimensional tolerances must be taken into consideration due to the installation of the rotor inside it. The specific materials of the rotor and its balance and the choice of the type of bearings used and the angles of its blades are very important, which makes its construction difficult.

Founded:

2010

Application:

Measurement of gas consumption of industrial units

This product is final B2B equipment.

Technical Specifications:

Flow measurement	Between 5 and 6500 cubic meters per hour
Pressure class	300 ,600 and 150 ANSI
G-rate flowmeter	65 to 4000 G
Nominal size of the flowmeter	12-2 in



Application:

Converting the kinetic energy of gases into rotational energy in oil transmission lines

➤ **Fundamental Overhaul of SGT 100 Turbine**

🏠 Carno Co.

www.carnogroup.com



Product Introduction:

A gas turbine is a rotating machine that works based on the energy of combustion gases. Each gas turbine includes a compressor to compress air, a combustion chamber to mix air with fuel and ignite it, and a turbine to convert the energy of hot and compressed gases into mechanical energy. Part of the mechanical energy produced in the turbine is used to turn the compressor of the turbine itself and the rest of the energy, depending on the application of the gas turbine, may turn the electricity generator (turbogenerator) or drive the compressor of gas stations (turbocompressor) or create propulsion in airplanes (turbojet). All turbines work according to the rule that air is drawn into a tube-like container and compressed, mixed with fuel and burned and exits at a high speed. The power turbine, which takes its kinetic energy from the hot gases coming out of the combustion chamber, rotates the compressor and other moving parts of the engine. The exhaust gas from the combustion chamber, which has a lot of energy, hits the turbine and turns it.

Main Export Destinations:

Turkey

Export History:

Up to 500,000 \$

Founded:

2008

This product is final B2B equipment.

Technical Specifications:

Turbine shaft rotational speed	22300 rpm
Operation power	1800 kW
Functional frequency	55 kHz
Heating rate	12000 kJ/kWh



► Repairing the Hot Section Parts of Neopinion and GE-F5 Turbines Including Fixed and Moving Blades, Liners and Transition Pieces

◆ Mabna Touss Co.

www.mabnatouss.com

مابنا توسس
شرکت مهندسی تعمیرات و نگهداری توربینها
Mabna Touss

Product Introduction:

In general, the parts that are in the combustion chamber of gas turbines are classified as hot parts. Due to very specific working conditions due to high temperature and wear and also mechanical stresses on these parts, their material, geometry and coating have special and complex technology. The geometry and dimensions of these parts, especially the vanes and liners, are very accurate and the specific curvature of each vane is determined by complex fluid and heat transfer calculations. Based on the standard of gas turbines, these parts should be overhauled after a specific operation depending on the type of part. In these repairs, all parts are taken apart and must be rebuilt. The most important part of the reconstruction is related to the hot parts and especially the turbine blade.

This product is final B2B service.

Technical Specifications:

- ※ **Material of the parts:** High temperature nickel superalloys
- ※ **Blade surface coating:** MCrAlY coatings and ceramic coatings

Founded:

2004



Knowledge-Based Products and Equipment

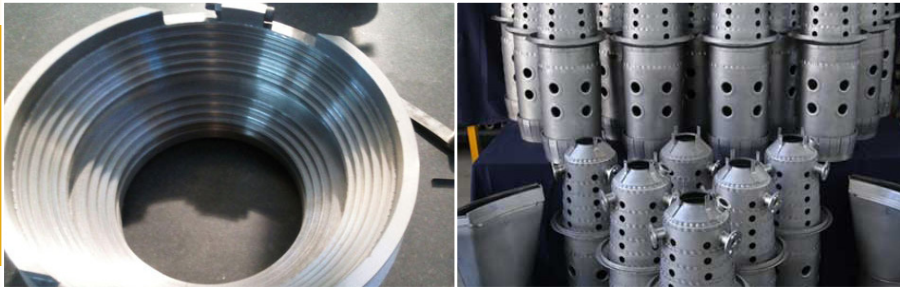

● PT Rotor of Solar Saturn Gas Turbine and the Blades of 4th and 5th Rows of the PT Section of Sulzer Gas Turbine and the Stator Blades of the AC Section of Solar Saturn Turbine

◆ Alborz Turbo Compressor Co.

www.alborztc.com



Product Introduction:

In order to redesign and manufacture these components, after determining the geometry of the components and dimensional and geometric tolerance and determining the material, the parts are produced by machining from Rod Forging. During this process, the dimensional control of the produced parts was done with CMM, and a control fixture was not designed and built.

The determination of the airfoil of the blades is done after preparing the cloud points and by the CATIA software. In this software, several sections are determined and the SWEEP command of the software is used. This command connects these sections in such a way that the smoothest line (Blade Stacking Line) passes through the center of the entire surface of the blade body. Because this line must be perpendicular to the disk axis.

This product is final B2B equipment.

Founded:

2010



Knowledge-Based Products and Equipment

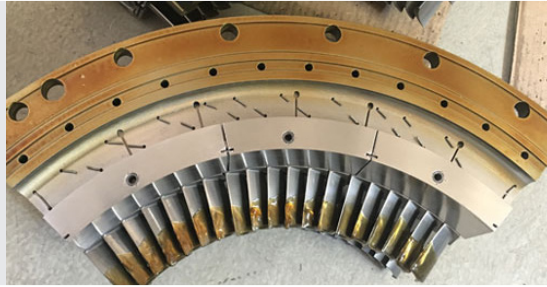

➤ Honeycomb Mesh and Seal

Used in Gas Turbines and Centrifugal Compressors

◆ Alborz Turbo Compressor Co.

www.alborztc.com



Product Introduction:

Honeycomb seals, which are used in the shell of axial or centrifugal compressors, control the condensing flow regime by preventing excessive flow disturbance and even calming the flow, and minimize the effect of temperature fluctuations and disturbance on the vibration of the rotor. These seals consist of two parts: mesh and metal bed. The metal bed is produced by machining. Meshes are made of spot welding of strips bent together with a special flexible pattern. Finally, these meshes are installed on the metal bed by brazing method.

This product is a final B2B consumer product.

Founded:

2010



Knowledge-Based Products and Equipment



➤ Ruston TB4000 Gas Turbine Overhaul

◆ Alborz Turbo Compressor Co.

www.alborztc.com



Product Introduction:

The gas turbine needs basic and super heavy overhauls in the long term, because the components of the turbine are under the influence of various metallurgical damages such as creep, fatigue, corrosion and abrasion during operation, the important effects of which can be the reduction of life of parts. For example, the expected life of a combined cycle power plant is 30 to 40 years, but the design life of a gas turbine is 10 to 15 years (3000 start or 100 to 120 KEOH). Meanwhile, the life of the components of the hot section is also shorter. The operating life of a turbine is influenced by the type and quality of fuel, turbine loading cycles, the number of starting frequency and operating environment. The time required for the rotor to operate before the RI inspection depends on various conditions such as the amount of load in operation, the operating hours of the unit, the number of start-ups in different conditions, the number of stoppages of the unit due to various problems, the type of fuel used in the unit and other mechanical and environmental conditions.

Founded:

2010

Application:

Converting fuel energy into other forms of energy such as electrical and mechanical

This product is final B2B service.

Technical Specifications:

The RI process includes the following steps:

- ✦ Examining the condition of the unit and collecting the necessary information (vibrations and production power, etc.) before removing the turbine from the operation network.
- ✦ Isolating the turbine from the fittings
- ✦ Checking the turbine instrumentation and their calibration
- ✦ Dismantling the rotor at the employer's site and transferring it to the operational workshop
- ✦ Dismantling the rotor into small parts
- ✦ Inspection of parts and examination of the condition of parts in order to generalize the use of parts, necessary repairs or replacement with new parts.
- ✦ Disc and rotor assembly
- ✦ Disc and rotor balance
- ✦ Transferring and placing in the main position on the employer's site

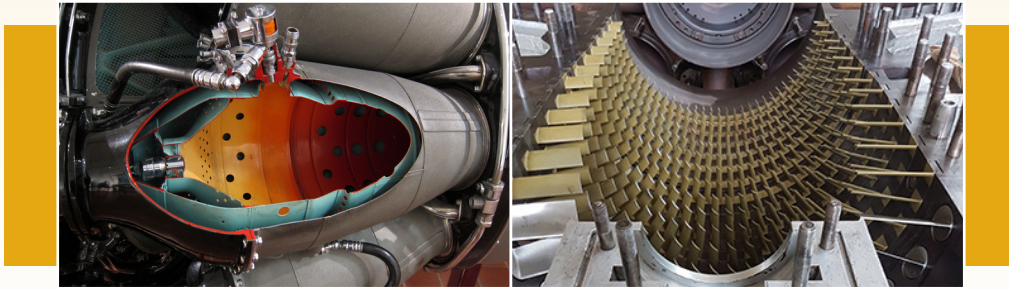

➤ Combustion Chamber of WERKSPOOR W72M Gas Turbine

◆ Alborz Turbo Compressor Co.

www.alborztc.com



Product Introduction:

In gas turbines, after leaving the compressor and distributor, the compressed air enters another part, where it is mixed with the appropriate amount of fuel and ignited, increasing the kinetic energy of the air passing through the engine. Some of this energy is used to turn the turbine and compressor, and the rest is sent out as high-speed gases from the outlet opening and creates driving force. The combustion chamber is one of the most important and complex parts of the gas turbine, where the heat added in the Brayton cycle enters the process. The temperature of the air entering the combustion chamber depends on the pressure, the operating load of the turbine and the type of machine and whether or not it is regenerated and can vary between 350 and 860 degrees Celsius. Also, the temperature of the gas exiting the combustion chamber will vary between 1000 and 1650 degrees Celsius depending on the turbine and its class in different parts of the chamber.

Founded:

2010

Application:

In ferrous and non-ferrous metal industries, as a passage for the melt

This product is final B2B equipment.

Technical Specifications:

Turbine power	8530 hp
Fuel	Natural gas
The mass flow rate of gas exiting the turbine	123 lb/s
Power turbine rotor speed	5200 rpm
Number per turbine	6 sets



► Blades of Cold Section of Gas Turbine (Compressor) and Steam Turbine

◆ Faradid Turbo Sanat (FTS) Co.

www.turbosanat.com



Product Introduction:

Fixed and moving blades are the most important parts of turbines, which have a complex geometry in terms of shape and dimensions. Shroud, airfoil, platform, root and fillets are important parts of a turbine blade. The main task of turbine blades in gas and steam turbines is to convert the kinetic energy of the hot fluid into rotational energy. In turbines, due to the high temperature and speed of the equipment, high stresses are applied to the parts and blades of the turbine; Therefore, these parts are made of special alloys and are balanced with very high precision, and are installed on the rotor. Different types of coatings are applied on the parts to protect these parts against special working conditions and also to increase the life of the part. In addition to geometry, materials and special production methods for this type of parts, a special quality control process is also performed in this case.

Founded:
2013

Application:

Used in industries such as power plants, oil and petrochemicals

This product is final B2B equipment.

Technical Specifications:

Steam turbine blades	<ul style="list-style-type: none"> * Material: Ductile cast iron * Installation location: The last rows of the LP part of the steam turbine
Blades of the cold section of the gas turbine	<ul style="list-style-type: none"> * Installation location: Compressor part

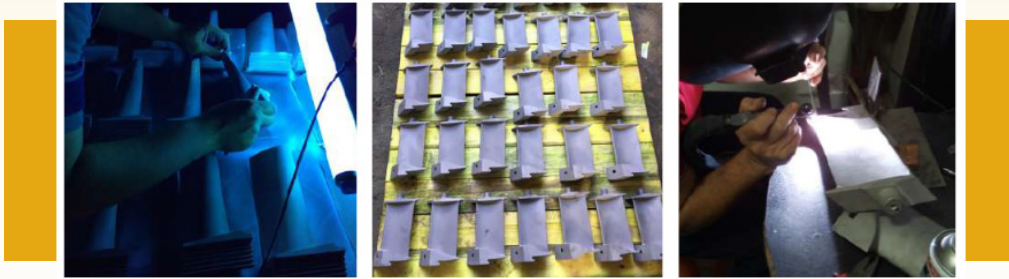

➤ Shroud Block Segment of Gas Turbine

◆ Faradid Turbo Sanat (FTS) Co.

www.turbosanat.com



Product Introduction:

This product forms the fixed components (fixed blades) of the turbine and related parts. Fixed and movable blades are the most important parts of turbines, which have a complex geometry in terms of shape and dimensions. Shroud, airfoil, platform, root and fillets are important parts of a turbine blade. The main task of turbine blades in gas and steam turbines is to convert the kinetic energy of the hot fluid into rotational energy. In turbines, due to the high temperature and speed of the equipment, high stresses are applied to the parts and blades of the turbine; Therefore, these parts are made of special alloys and are balanced with very high precision, and are installed on the rotor. Different types of coatings are applied on the parts to protect these parts against special working conditions and also to increase the life of the part. In addition to geometry, materials and special production methods for this type of parts, a special quality control process is also performed in this case.

Application:

Used in industries such as power plants, oil and petrochemicals

This product is a final B2B equipment.

Founded:

2013



Knowledge-Based Products and Equipment



► Coreless Blades of the Hot Section of the Gas Turbine

◆ Faradid Turbo Sanat (FTS) Co.

www.turbosanat.com



Product Introduction:

Fixed and moving blades are the most important parts of turbines, which have a complex geometry in terms of shape and dimensions. Shroud, airfoil, platform, root and fillets are important parts of a turbine blade. The main task of turbine blades in gas and steam turbines is to convert the kinetic energy of the hot fluid into rotational energy. In turbines, due to the high temperature and speed of the equipment, high stresses are applied to the parts and blades of the turbine. Different types of coatings are applied on the parts to protect these parts against special working conditions and also to increase the life of the part. In addition to geometry, materials and special production methods for this type of parts, a special quality control process is also performed in this case.

Founded:

2013

Application:

Use in power plants, oil and petrochemicals industries

This product is final B2B equipment.

Technical Specifications:

Material	Special nickel-chromium-cobalt alloys
Installation location	The second row after the turbine
Service temperature	About 700-800 degrees Celsius



➤ Coreless Diaphragm of Gas Turbine

Nozzle Without Core and Upper and Lower Rims of Fixed Blade

◆ Faradid Turbo Sanat (FTS) Co.

www.turbosanat.com



Product Introduction:

The working principle of centrifugal compressors is to use centrifugal force to increase the kinetic energy of gas. This action is applied to the fluid by vanes installed on the propeller. In this type of compressor, the main factor of energy transfer is the compressor impeller, which is installed on the axis and rotates with it. After the fluid enters the fountain, the impeller is guided on the blades that are installed on it and will enter the chamber around it so that the received kinetic energy is converted into pressure energy. These types of compressors are the most used in the industry and they are used to compress air and other gases in different volumes and pressures. One of the types of centrifugal compressors is DIFFUSER CASING COMPRESSORS. In these compressors, the impeller is surrounded by fixed vanes called diffuser vanes (DIFFUSER). The diffuser vanes are mounted on the compressor shell and the fluid passing through the impeller enters the diffuser vanes. The diffuser vanes are mostly used in high pressure multi-stage compressors.

Diaphragm is part of the body of multi-stage centrifugal compressors and is a replaceable wall that is placed between the impellers of different stages of the compressor.

Application:

One of the main parts of centrifugal compressors

This product is final B2B equipment.

Founded:

2013

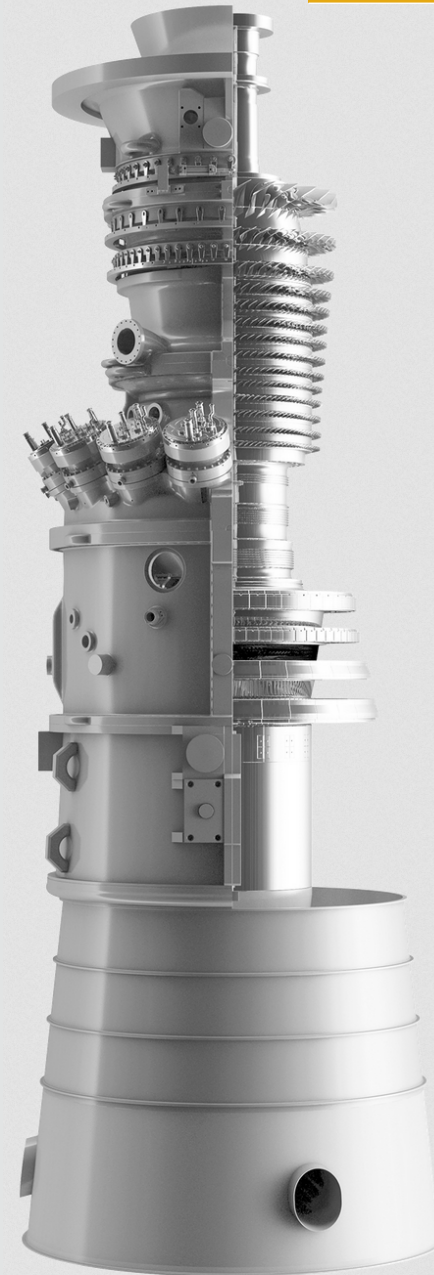



➤ Updating DCS Control System and Gas Turbine Protection

◆ Nik Andishan Energy Co.

www.nicaco.com



Product Introduction:

DCS (Distributed Control System) automation system is one of the smartest systems used in factories and control centers. Each system component, such as the data management and access section, processing management and graphic display and data collection unit, has its own function. Communication between each element in the factory is done through a distributed computer, which is also called "control network". The main component of the factory is the "distributed control system", which is used to automatically make decisions according to the real-time update of product information throughout the factory. For example, a DCS device used in a power plant automatically increases the steam generation capacity of the various turbines to match the increase in electricity demand when the temperature rises and decreases again when the temperature drops.

Application:

- * Monitoring turbine and generator parameters
- * Updating the control system based on the controllers available in the market instead of the old control system
- * Improving the protection system by using electronic relays instead of old mechanical protection relays

This product is final B2B service.

Founded:

2014

Energy & Power Plant Industries

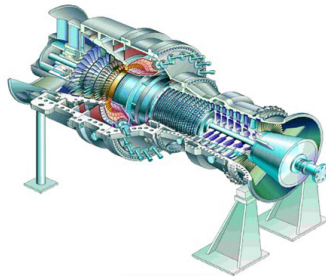

Knowledge-Based Products and Equipment

**Application:**

Alloy used for combustion chambers and hot gas passages

► Reconstruction and Repair of Innercasing, Mixing Chamber and Liner of Gas Turbine V-942 and BBC13D

◆ Paya Mavad Technological Co.

www.payamavad.com

**Product Introduction:**

The combustion chamber (mixing chamber) of the gas turbine is the part that is located between the compressor and the turbine, and its task is to burn fuel and increase the temperature of the incoming air. The internal wall (innercasing) is a part whose task is to transfer the combustion products from the combustion chamber to the turbine. The mentioned parts are subject to various damages during operation such as creep, oxidation, corrosion, wear and fatigue. Placing this alloy at temperatures higher than 700 degrees Celsius over time causes the growth of sediments, especially in the grain boundaries, and also increases the distance between the sediments in the field. As a result, its mechanical resistance is reduced and destruction takes place in the parts where there is more thermal concentration. These damages also causes damages to the parts, which in most cases can be repaired and returned to the cycle of use by adopting special technical and engineering procedures. Tracing the damaged parts and making arrangements such as annealing heat treatment, grinding, welding, tempering and final heat treatment are among the measures that cause the repair and restoration of the said parts. The reconstruction and repair of the mentioned defective parts, including innercasing, mixing chamber and liner of the SIEMENS V94.2 and BBC-13D gas turbines, and production of the relevant technical knowledge for the first time in Iran were done at Paya Material Technology Company. Investigating the metallurgical microstructure, investigating the destruction mechanisms activated on the piece, designing the required heat treatment cycle, designing and manufacturing the required welding and heat treatment fixtures, and performing all the welding steps, dimensional correction and quality control are included in the reconstruction process.

Founded:

2004

This product is final B2B service.

Technical Specifications:

Material: Inconel 617 superalloy

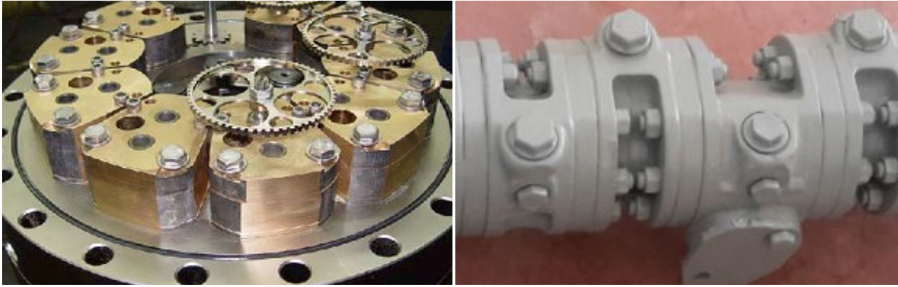

➤ GE Gas Turbine Flow Divider

◆ Safat Energy Yazd Co.

www.safatco.com



Product Introduction:

The flow divider is a part of the fuel supply system of gas power plants, which has the task of dividing the liquid fuel in the gas turbine. In each gas turbine, there are several combustion chambers in which the chemical energy of the fuel is converted into hot gas energy. The hot gas produced must be equally distributed throughout the turbine between the combustion chambers. The difference between the fuel flow rate causes temperature differences in different parts of the turbine, creates mechanical and thermal stresses on the parts, and reduces the useful life of the hot parts of the turbine and reduces the thermal efficiency. The flow divider distributes the liquid fuel in the gas turbine.

Founded:
2010

Application:

Distribution of liquid fuel in gas turbine in gas power plants

This product is final B2B equipment.

Technical Specifications:

Main components:

- * The main body
- * pump
- * Main gear
- * Pick-up gear
- * Starter motor
- * Fuel inlet
- * Fuel outlet

**Application:**

Gas turbine fuel distributor

➤ Fuel System of Industrial and Power Plant Turbines

◆ Safat Energy Yazd Co.

www.safatco.com

**Product Introduction:**

This system consists of a large number of parts for fueling the gas turbine, which include flow divider as a fuel distributor, check valve for one-way flow of fluid, lock washer, sealing gasket, servo valve, and all of them are made through casting and machining, etc.

Founded:

2010

This product is final B2B equipment.

Technical Specifications:

Dimensions	About 3 × 2 m
Height	About 1.3 m
Approximate weight	About 800 kg
Required electrical power	25 kW

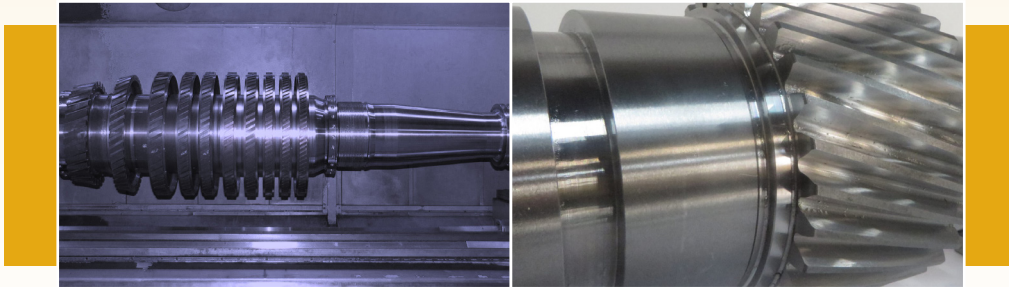

➤ **Gas Turbine Rotor with RPM (3000-30000) and Power (3-25 MW)**

🏠 **Irsa Machine Development Co.**

www.irsamachine.com



Product Introduction:

Gas turbine rotor includes two parts PT rotor and GG gas turbine rotor. The GG rotor of gas turbines has the task of supplying and compressing the air required by the turbine for combustion and cooling the gas resulting from combustion in the combustion chamber (for example, the SGT600 turbine with a pressure of about 15 bar and a flow rate of about 80 cubic meters per minute at a working speed of 10500 rpm).

The PT rotor of gas turbines also has the task of converting the kinetic energy of the gas caused by combustion into mechanical energy and moving the gas transfer compressor or the generator connected to the PT rotor. These rotors consist of several disks connected to each other and the main shaft that is connected to the disk.

Founded:
2010

Application:

All industrial turbines used in the oil, gas, refining and petrochemical industry, gas turbines in the electricity industry, air engines, etc.

This product is final B2B equipment.

Technical Specifications:

Material of the disks	Superalloy
Geometrical tolerance of discs	5 μ
Rotational speed	3000-30000 rpm
Power	3-25 MW

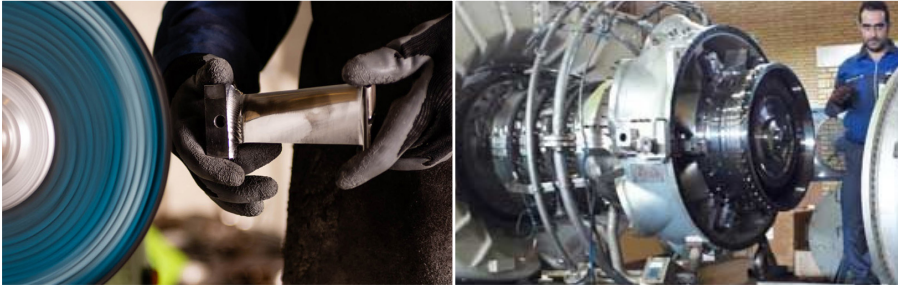

➤ Overhaul of Gas Turbines (Including Disassembly, Inspection of Parts, Manufacturing of Auxiliary Parts, Balance and Assembly)

◆ Badr Engineering Systems Co.

www.badrssystem.com



Product Introduction:

SGT400 can be introduced as the smallest gas turbine on a power plant scale (made by Siemens, Germany) in which a two-variable turbine is considered. The first turbine of this type with a rated power of 9.13 MW was released in 2000. In 2008, it was introduced as a package and as a mechanical motor for rotating equipment, and its upgraded version with a rated power of 15 megawatts was delivered to the market. The use of the IGV system in the first five stages of the compressor is one of the features of this gas turbine. This feature provides different working conditions with the best efficiency and is designed and built for both the needs of electricity generation and mechanical engine of rotating equipment. Rebuilding a gas turbine after a certain period of operating requires dismantling all its parts.

Founded:

1992

Application:

Electricity generation and mechanical engine of rotating equipment

This product is final B2B equipment.

Technical Specifications:

During the overhaul of this turbine, before the disassembly of the turbine, the overall condition of the turbine is checked using a borescope. After preparing a report on the condition of the delivered turbine before disassembly, the turbine shell (turbine nozzle and diffuser) is first separated from it; Next, the three parts of compressor, combustion chamber and turbine are disassembled from the main shaft. Then the sub-systems such as exhaust, accessory drive, combustion chamber are disassembled and also in order to rebuild the compressor, liners, movable blades and compressor discs will be disassembled separately. After disassembly for initial inspection, the parts are washed and cleaned. Next, the parts are subjected to preliminary examination to determine whether they need to be replaced or not. After receiving repair parts and preparing replacement parts, parts and systems are reassembled. In the meantime, the blades on the discs are aligned and balanced, and each one is assembled on the balanced shaft based on the Run Out.

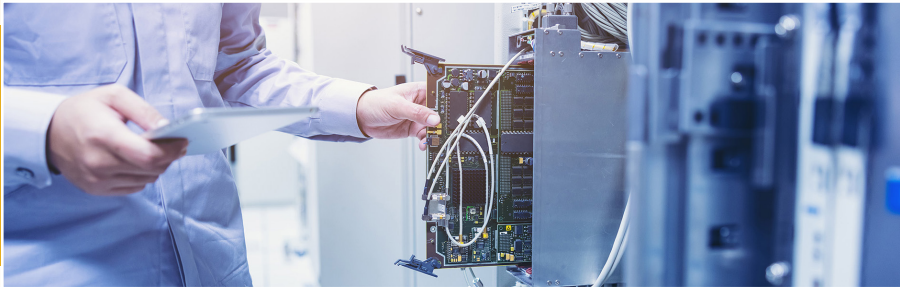

- **Power Plant Control Cards | Including:** DCS Extended Control System Cards, Allen Bradley PLC-5 System Cards, ESD Prosafe System I/O Cards, CCC Gas Turbine Control System Cards, Bearing Control System Cards AMB and AMB V2 Magnetic Turbo Expander, FCV Controller Cards or Fuel Control Valve

- ◆ **Amvaj-e-Abi Electronics Industry Co.**

www.amvaje-abi.com



Product Introduction:

DCS distributed control system cards: Distributed control systems or DCS are a type of process control system in which control components, especially controllers, are distributed throughout the process. DCSs are mostly designed and built in the form of a multi-layered control structure, from the supervisory and management levels to the lower levels to control the local details of the process. The distributed control system is a set of controllers and can receive the required signals and issue the necessary commands through its input-output units. Communication between controllers is also done through standard industrial networks. It can be said that a DCS is a suitable system for controlling processes in large industries.

Allen Bradley's PLC-5 system cards: PLC system, which means programmable logic controller, is considered an indispensable part of industrial systems and its task is to supervise, control and monitor industrial processes. PLC is a software controller that receives inputs through input cards, processes them according to the program stored in its memory, and then sends the result of the operation through output cards in the form of commands to the receiver and executor of the command.

Prosafe ESD system I/O cards: ProSafe PLC system (Programmable Safety systems) is an industrial protection system and has the ability to perform all

Founded:

2002

the usual safety tasks. Moreover, this system has the ability to perform non-safety functions that include man-machine interface (MMI), distributed control systems (DCS), sequence of event recording (SER), and connection to the SCADA system. **CCC gas turbine control system cards:** At the output of refineries and gas pressure boosting stations, several turbo compressors are used to boost gas pressure, and one of the control systems for such turbines is the CCC control system. This system is a set of processor, communication, input/output, power and isolator and signal converter electronic cards, whose three major and important functions include "control of starting and stopping conditions", "control of normal working conditions", "protection and safety controls", monitoring and communication with upstream control systems such as DCS and SCADA and ESD in turbo compressors. Due to the practical sensitivity of this system, high protection and safety are considered in its design.

Turboexpander AMB and AMB v2 magnetic bearing control system cards: Active Magnetic Bearing (AMB) system is designed and manufactured for the stability of magnetic bearing suspension. After starting to work, these bearings are suspended by magnetic force to minimize the friction of the axis, and the produced AMB system, has the task of controlling and monitoring various parameters of this process, such as suspension in axial and radial directions (X, Y, Z), bearing temperature, speed of rotation, etc.

FCV control cards or Fuel Control Valve: As the name suggests, FCVs are the fuel control valves of turbines. Since gas turbine speed control is done through turbine fuel control, it is important to control the turbine input fuel with very high speed and response time. This recommendation becomes doubly important especially in cases where the turbine speed control has a higher sensitivity (such as GTG turbines where the generator output is synchronous with the grid); Therefore, the functional sensitivity, response speed, accuracy and resolution of the FCV or fuel control valve have a significant effect on controlling the correct operation of the turbine. Due to the required sensitivity and high speed, FCVs are mainly designed and manufactured using stepper motors.

This product is final B2B equipment.

Application:**DCS distributed control system cards:**

- * Industrial automation systems
- * Gas and petrochemical refinery
- * Power plants

Allen Bradley PLC5- System Cards:

- * Energy conversion industries
- * Petrochemical and refineries, gas pressure boosting stations, power generation stations, industrial wastewater treatment systems, gas treatment and recycling systems
- * Machine industries

ESD Prosafe system I/O cards:

- * Chemical industries and extraction and refining of gas and oil, etc.

CCC gas turbine control system cards:

- * Pressure boosting and injection systems to the output lines of gas refineries
- * Gas production and transmission platforms
- * Pressure boosting stations of gas transmission operational areas, etc.

AMB and AMB v2 turboexpander magnetic bearing control system cards:

- * Suspension control of turbine axis and turboexpanders of oil and petrochemical industries
- * Suspension control of turbo compressors and pressure boosting turbo generators Rotary machines with high mechanical accuracy such as CNCs

FCV control card or Fuel Control Valve:

- * Turbo compressor speed control
- * Turbo generator speed control
- * Speed control of GTCC combined cycle turbines

Technical Specifications:**DCS distributed control system cards:**

- * Standard Ethernet network connection as Full Duplex with 100 MB/second speed
- * Power supply DC-DC 12/24VDC

Allen Bradley PLC5- System Cards:

- * 16-channel digital input and output card
- * 16-channel analog input card
- * Modbus communication card
- * Power supply card

ESD Prosafe system I/O cards:

- * 32 discrete channels of 24 or 48 volts
- * 16 voltage/thermocouple input channels
- * Isolation between field and bus data

AMB and AMB v2 turboexpander magnetic bearing control system cards:

- * Input control signal: DC 20-4mA
- * Power consumption: Maximum 600W
- * Position information signal: DC 20-4mA

FCV control card or Fuel Control Valve:

- * Input control signal: DC 20-4mA
- * Output stepp motor coil control signal: Minimum 100V
- * Power consumption: Maximum 600Ws

Advantages:**DCS distributed control system cards:**

- * The possibility of producing licenses compatible with DeltaV software
- * Automatic redundancy between -8channel I/O cards

Allen Bradley PLC5- System Cards:

- * Has high accuracy digital and analog cards and Modbus communication card

ESD Prosafe system I/O cards:

- * Separate programming capability for each channel as voltage input/thermocouple input
- * Built-in adjustable amplifier to adjust input range/accuracy

AMB and AMB v2 turboexpander magnetic bearing control system cards:

- * Reducing the number of system boards
- * Replacement of old parts with more appropriate and updated parts

FCV control card or Fuel Control Valve:

- * Reducing the number of system boards
- * Replacement of old parts with more appropriate and updated parts

International Standards or Permissions:

- * IEC61326-1
- * IEC61131-2
- * IEC60068-2-1
- * IEC60068-2-2
- * IEC60068-2-30



➤ Major Repairs of Gas Turbine Model DU80L

◆ **Niroo Mechanic Asia Co.**

www.niroomechanic.ir



Product Introduction:

In turbines, important issues such as surge, stall, hot spot, creep and misfire occur, and ignoring them will cause serious damage to the unit.

Stall or separation phenomenon: Whenever the speed of the fluid passing through the compressor vanes is such that the fluid is separated from the back of the vane, eddy currents are created behind the vane, and as a result, the compressor cannot create the necessary pressure at the vane outlet, this phenomenon is called STALL (separation).

Surge phenomenon: Any factor that causes the compressor to not be able to produce the previous necessary pressure (pressure at the inlet of the vane) and as a result, the pressure at the outlet of the compressor is more than the original pressure (input) of the compressor, the output fluid tends to return to the entrance, and also the collision of high-pressure and low-pressure masses and change of flow direction, which leads to vibration and high noise, are also called surge.

Hot Spot Phenomenon: When the pressure difference between the fuel that pours through the nozzle in the combustion chamber (P_{fuel} Gas) and the incoming air exceeds the permissible limit, a flame is created in the end part of the combustion chamber and causes the primary blades of the turbine to burn. They are exposed to the flame and get hot and burnt. This phenomenon is called Hot Spot.

Misfire phenomenon: If in the turbine, the combustion turns into an explosion due to some reasons, a sudden increase in the pressure in the combustion chamber will be caused and the air flow will return to the axial compressor, which results in the surge of the axial compressor. Among the causes of MIS FIRE is the entry of excessive fuel into the combustion reservoir during start-up or a sudden increase in the ratio of fuel and air during operation.

Founded:

2009

Application:

- * Used in a power plant by connecting with a generator to produce electricity
- * Military and transportation industries such as ships and submarines
- * Use in oil industries

This product is final B2B service.

Technical Specifications:

- * **Output power:** 25.6 MW
- * **Efficiency:** 35.6 %
- * **Output gas flow rate:** 87Kg/s
- * **Output temperature:** 480°C

**Application:**

Converting kinetic energy of hot fluid into rotational energy

➤ Cold Section Blades of Gas Turbine and Steam Turbine Blades

◆ Niroo Mechanic Asia Co.

www.niroomechanic.ir

**Product Introduction:**

Fixed and moving blades are the most important parts of turbines, which have a complex geometry in terms of shape and dimensions. Shroud, airfoil, platform, root and fillets are important parts of a turbine blade. In the turbine, due to the high temperature and speed of the equipment, high stresses are applied to the parts and blades of the turbine. Therefore, these parts are made of special alloys and are balanced with very high accuracy, and are installed on the rotor. Different types of coatings are applied on the parts to protect these parts against special working conditions and also to increase the life of the part. In addition to using geometry, materials and special production methods for this type of parts, a special quality control process is also performed in this regard.

The fixed and moving blades of the turbine, which are installed in its cold section, play a vital role in the operation of the turbine and increase its efficiency, to the extent that the smallest error in the construction or design of these parts causes the loss of turbine efficiency or brings the turbine's operating conditions closer to the state of surge and instability. Due to the high speed of small turbines, the smallest contact resulting from interference of parts due to surge will cause irreparable damage to the turbine.

Founded:

2009

This product is final B2B equipment.

Technical Specifications:

In general, the process of making a blade includes the following steps:

- * CMM and the production of cloud points and 3D map production
- * Material selection through the material analysis of the depreciated sample
- * Preparation of raw forged material
- * Converting the 3D design to GCODE for sending to CNC machines and blade machining and finally sub-cutting the blades.
- * Final quality control of blades



➤ Machining and Production of Gas and Steam Turbine Blades

🏠 Pishro Sanat Daghigh Co.

www.psdiran.ir



Product Introduction:

The turbine blade is the most important part of the gas and steam turbine. The construction of turbine blades is very important due to the high mechanical and dynamic loads exerted on them. The different areas of the blade include shrouds and sealing areas, airfoils, shock holes and cooling holes and roots, and each area will be made in different ways depending on the type of blade (aeronautical industry or other industries, compressor or turbine). In general, to make a turbine or compressor blade, first the raw material is made into the desired initial shape by one of the precise forging or casting methods; Then, in order to reach the final size of the different parts of the blade, they use different machining methods. The most precise part of the blade in terms of dimensions is its root part, which usually uses special methods for its machining.

Founded:
2006

Application:

Energy extraction from gas with high temperature and high pressure produced in the combustion chamber of the turbine

This product is final B2B equipment.

Technical Specifications:

Blade material:

- * Superalloy and steel and nickel based alloys such as NI80, NI90, ST410

The main parts of the blade:

- * Root
- * Platform
- * Airfoil

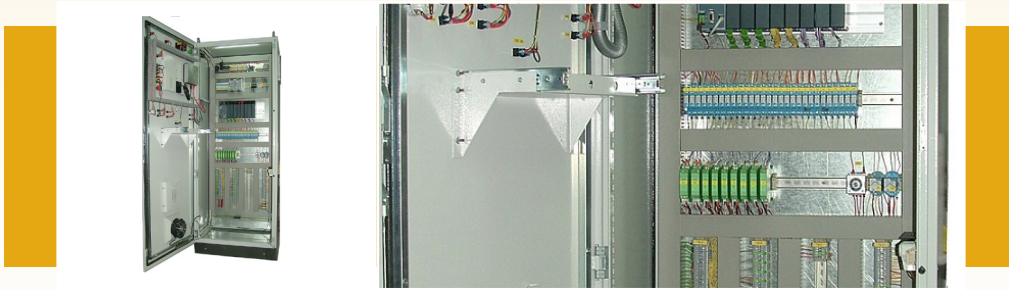

Application:

Repair and reconstruction of gas and steam turbine parts (in carbon steel welding and penetration welding of stainless steel and non-ferrous metals)

➤ **Solar Turbine Control System**

◆ **Contronic Technology Electronics & Control Systems Co.**

www.contronic.net



Product Introduction:

This product is a solar turbine control panel made in the US and a turbine made by the Khavar Mianeh Turbine Machine Company with a power of 400 kW. Turbopumps are high-power mechanical equipment that receive energy from gas and convert it into mechanical torque so that it can be used to move fluids such as oil and gas. The structure of turbo pumps is such that a pump is coupled to a turbine. Considering the pressure of the pipelines, this turbine has the ability to work with variable rates. The main controller of the solar turbine control panels includes a PLC500 Nseries device and a number of signal conditioners in different types.

Founded:

1981

This product is final B2B equipment.

Technical Specifications:

Dimensions	600 × 900 × 2100 mm
Controllers	PLC 500 Nseries
Operating, displaying monitoring pages and collecting and recording values	MiniPC device with Windows 10 operating system

International Standards or Permissions:

IEC 61131-3



Application:

For spraying and pulverizing the fuel for combustion in the RUSTON TA turbine in the combustion chamber

➤ **Ruston TA 1750 Gas Turbine Burner**

◆ Azar Energy Pardis Co.

www.pardis-energy.com



Product Introduction:

A gas turbine is a rotating machine that works based on the energy of gases produced by combustion. Each gas turbine includes a compressor to compress air, a combustion chamber to mix air with fuel and ignite it, and a turbine to convert the energy of hot and compressed gases into mechanical energy. A burner is required for proper combustion; Because the fuel must be powdered so that the fuel droplets can evaporate faster. Fuel powdering is done by a pulverizer. In addition to pulverizing the fuel and turning it into fine particles, burners create a disturbance between air and fuel which causes a uniform mixture of air and fuel.

Founded:
2017

This product is final B2B equipment.

Technical Specifications:

Arrangement of burners in the furnace	Has different designs
Turbine burner	Including Main and Pilot sections

International Standards or Permissions:

- * ISO 1101
- * ISO 128
- * ISO 2768

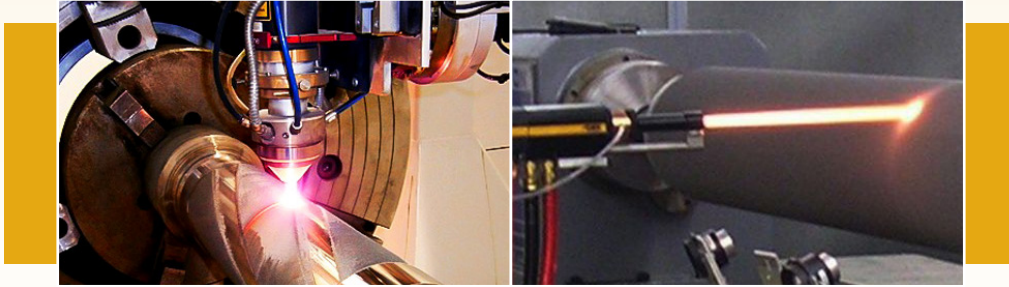

► Repair and Reconstruction Services of Gas and Steam Turbine Parts Using the Plasma Transferred Arc Welding (PTAW) Method

◆ Behinkaran Chehelsotoon Co.

www.behinkaran.com



Product Introduction:

Plasma Transferred Arc Welding is an electric arc welding process similar to gas tungsten arc welding (GTAW). An electric arc is established between the electrode (which is usually but not always made of porous tungsten) and the workpiece. The main difference between this process and GTAW is that in PTAW, depending on the position of the electrode inside the torch body, the plasma arc can be separated from the protective gas cover; Also, the filler used in this method, instead of the electrode wire, is the desired powder, which makes it possible to change the percentage of some elements or add ceramic particles so as to create a metal base composite with ceramic particle reinforcement. In this process, an electric arc is established between the electrode, which is the negative pole, and the workpiece, which is the positive pole. In other words, the electric arc is transferred from the electrode to the workpiece. The transferred arc has a high energy density and a high plasma jet speed, therefore it is suitable for melting metals.

Application:

Repair and reconstruction of gas and steam turbine parts (in carbon steel welding and penetration welding of stainless steel and non-ferrous metals)

This product is final B2B service.

Technical Specifications:

First phase: initial investigation and laboratory phase	<ul style="list-style-type: none"> * Metallurgical and mechanical examination of used parts and characterization of the part * Cladding operations on the prototype * Quality control and process verification
The second phase: modification and reconstruction of the main piece	<ul style="list-style-type: none"> * Installation of equipment and implementation of the reconstruction process * Quality control * Final control after initial machining

Advantages:

- * Using parts made of alloys with favorable mechanical properties and very high fatigue resistance
- * Very high accuracy of parts dimensions

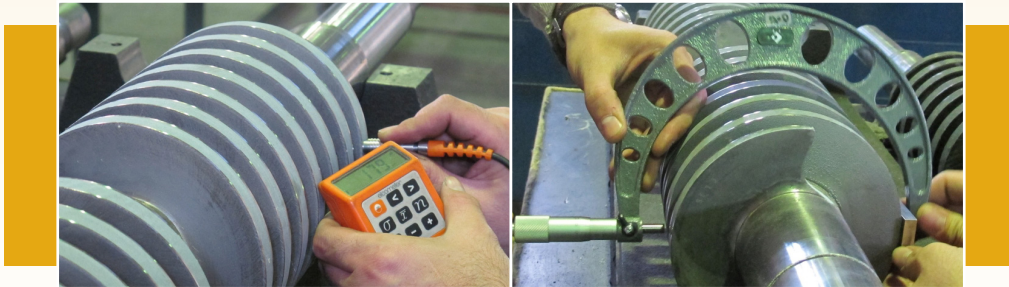

➤ **Testing and Alignment Services of V94.2, GE-F9 and MHI Turbine Fuel Injectors**

◆ Arshia Co.

www.arshiaco.com



Product Introduction:

The combustion process in turbines is performed through a sensitive and important part called fuel injector. It is possible to supply the necessary combustion for the rotation of the turbine and generator and the production of electricity with the help of fuel injectors; For this purpose, it is necessary to inject fuel with high pressure (about 50 bar) into the fuel injector.

The fuel injector, with its special mechanism, turns this fluid into a powdered form and places it into the combustion chamber with air in full rotation. At this stage, combustion takes place. Combustion products enter the turbine and cause it to rotate rapidly. Finally, the generator turns and produces electricity.

Founded:
2009

Application:

Carrying out the combustion process in turbines

This product is final B2B service.

Technical Specifications:

V94.3 Turbine	<ul style="list-style-type: none"> * Injection rate: 40 litres/min * Input pressure: 50 bar * Output pressure: 6-33 bar * Service temperature: 1100
MHI Turbine	<ul style="list-style-type: none"> * Injection rate: 32 litres/min * Input pressure: 45 bar * Output pressure: 10-25 bar * Service temperature: 1150
GE-F9 Turbine	<ul style="list-style-type: none"> * Injection rate: 30 litres/min * Input pressure: 45 bar * Output pressure: 20 bar * Service temperature: 1150

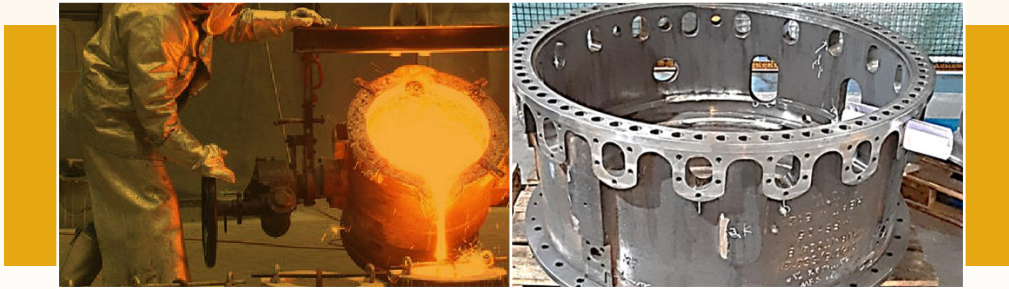

➤ Outer Casing and Stator Casing Parts of Gas Turbines Cast with Ductile Cast Iron GGG40

➤ Mateen Foulad Sepahan Co.

www.matinsteel.com



Product Introduction:

A gas turbine is an internal combustion engine of rotating machine type that works based on the energy of gases caused by combustion. Each gas turbine includes a compressor for compressing air, a combustion chamber for mixing air with fuel and igniting it, and a turbine for converting the internal energy of hot and compressed gases into mechanical energy.

Part of the mechanical energy produced in the turbine is used to turn the compressor of the turbine itself, and the rest of the energy, depending on the application of the gas turbine, may turn the electric generator (turbogenerator), accelerate the air (turbojet and turbofan) or be directly consumed in the same way (Turboshaft, Turboprop and Turbofan).

Application:

- * In power plants
- * In the engine of helicopter, passenger planes, war planes and most turbine ships

This product is final B2B equipment.

Technical Specifications:

Material of parts	Ductile cast iron GGG40
Components	OUTER CASING and STATOR CASING
The number of outer casing holes	316

International Standards or Permissions:

- * ASTM E3-2017
- * ASTM E 407-2015
- * ASTM E 883-2017
- * ISO 945-1 -2010

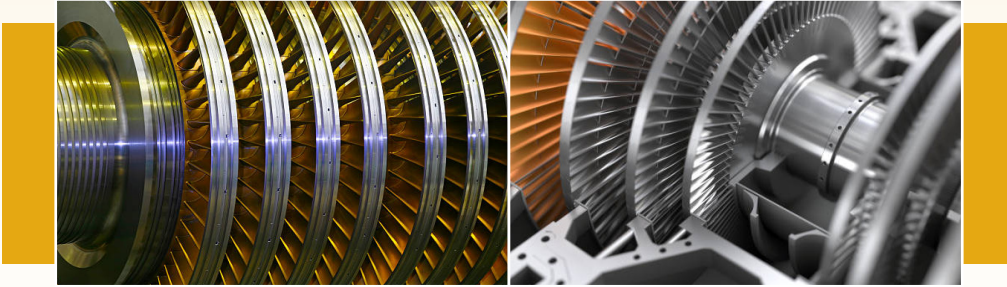

➤ C-Level Overhaul of SGT 100 and SGT 600 Gas Turbines

◆ Dimag Delaval Desoil Services Co.

Product Introduction:

Gas turbines are used in two general categories: industrial and power plant. In the first category, gas turbines are used to drive pumps and compressors in the form of turbocompressors or turbopumps. The gas turbine needs a periodical inspection in the time intervals determined by the manufacturer, because the turbine components are subject to various mechanical and metallurgical damages such as creep, fatigue, corrosion and wear during operation. The important effects of the mentioned damages are the reduction of the life of the parts. In order to periodically inspect the gas turbine in the time intervals determined by the manufacturer, the components of the turbine in the three stages of combustion chamber (Combustion Inspection), the hot section of the turbine (Hot Gas Path Inspection) and the entire turbine (Major Inspection) will be examined.

Application:

Fundamental overhaul of gas turbines

This product is final B2B service.

Technical Specifications:

Siemens turbines have another type of inspections and repairs from levels A to E based on Siemens' exclusive classification. Level C repairs are generally as follows:

1. Receiving the turbine
2. Turbine and rotor disassembly within the defined limits
3. Inspection of compressor blades and peripheral equipment
4. Cleaning the components and disassembled parts of the hot section
5. Non-destructive testing and accurate measurement of parts
6. Preparing a list of repairable and available parts
7. Remaking of parts (welding, machining, coating, etc.)
8. Rotor assembly
9. Rotor balance
10. Turbine assembly
11. Turbine testing and setup



➤ Overhaul, Troubleshooting and Major Repairs of MAN-THM 1304 Gas Turbine

◆ Kian Turbo Tec Co.

www.kianturbotec.ir



Product Introduction:

The gas turbine needs a periodical inspection in the time intervals determined by the manufacturer, because the turbine components are subject to various metallurgical damages such as creep, fatigue, corrosion and abrasion during operation. One of the important effects of the mentioned damages is the reduction of the life of the parts. For the purpose of periodic inspection, the gas turbine is inspected in the time intervals determined by the component manufacturer in three levels: combustion chamber (Combustion Inspection), hot section of the turbine (Hot Gas Path Inspection) and the entire turbine (Major Inspection). The main activity of the company is to provide this service on three MAN-THM 1304 turbines with operating hours of 31,000, 17,000 and 5,000 hours that have been delivered for overhaul. On the first turbine Major Inspection and on the other two turbines due to the failure of the first row compressor blade which led to the destruction of the GG, the inspection and replacement of defective parts were done.

This product is final B2B equipment.



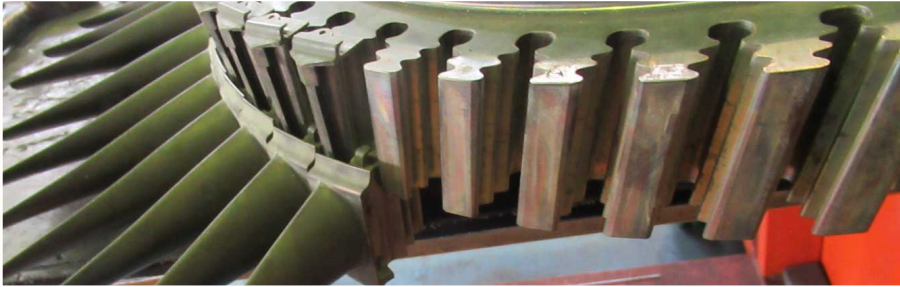

➤ Overhaul, Troubleshooting and Major Repairs of SOLAR-TAURUS 70 Gas Turbine Including Reconstruction of Hot Section Parts

◆ Kian Turbo Tec Co.

www.kianturbotec.ir



Product Introduction:

The gas turbine needs a periodical inspection in the time intervals determined by the manufacturer, because the turbine components are subject to various metallurgical damages such as creep, fatigue, corrosion and abrasion during operation. One of the important effects of the mentioned damages is the reduction of the life of the parts. For the purpose of periodic inspection, the gas turbine is inspected in the time intervals determined by the component manufacturer in three levels: combustion chamber (Combustion Inspection), hot section of the turbine (Hot Gas Path Inspection) and the entire turbine (Major Inspection). The SOLAR-TAURUS 70 turbine is among the third generation turbines, which has blades with advanced manufacturing technology such as single crystal, and the overhaul, supply and repair of these parts are exclusively available to the manufacturer. For the purpose of Major Inspection, generally, after dismantling the turbine shell, a general inspection is done and a report is prepared.

This product is final B2B equipment.





➤ 160 MW MST-50C Steam Turbine

◆ Mapna Turbine Engineering & Manufacturing (TUGA) Co.

www.mapnaturbine.com



Product Introduction:

Mapna's two-pressure steam turbine named MST-50C was built with the aim of responding to the customer's need for a turbine with low maintenance and repair time and cost. This turbine has the ability to work in difficult conditions and has been supplied to produce electricity with a high availability factor. The MST-50C turbine has two steam inlets with different pressures and is used in combined cycles. The power of this turbine is 160 MW and the combined cycle efficiency reaches 50% using this turbine and two MGT-70 gas turbines. The turbine is double pressure and condensing type.

Main Export Destinations:

Germany, Italy, Switzerland, UAE

Export History:

Up to 500,000 \$

Founded:

1999

This product is final B2B equipment.

Technical Specifications:

Gross output power	160 MW
Frequency	50 Hz
Main steam temperature	520°C
Weight (main engine)	159 tons
Dimensions	5 × 4.7 × 6.7

Advantages:

- ✦ Increasing the mechanical and vibrational resistance of blades with SHROUD installation
- ✦ Reducing heat loss by designing an inner shell for the high pressure section
- ✦ Integrated design of main steam valve body



➤ Redesigning and Manufacturing the Blades of the Low-Pressure Section of Steam Turbines

◆ Iran Power Plant Repairs Co.

www.ipr-co.com



Product Introduction:

Steam turbine blades are considered important parts of the turbine. These blades convert the linear movement of steam with high temperature and pressure into the rotational movement of the turbine shaft. If these blades are broken, the unit will shut down. This issue will have many economic consequences for the power plant. The blades of the low pressure section of steam turbines usually have a height of more than 500 mm, and their end part includes a shroud. Damping wire is used in the middle part of these blades to reduce vibrations and the damage to the blade and, as a result, increase the working life of these blades. The main function of the damping wire is to dampen the forced vibrations during the operation of the turbine set, which passes through the airfoil hole of the blade.

Founded:

1990

Application:

Redesigning and manufacturing the low pressure blades of steam turbines in the power plant sector

This product is final B2B equipment.

Technical Specifications:

The steps of reverse engineering of these blades are as follows:

1. Selection of materials
2. Vector points / scanning the cloud of points
3. Modeling and preparation of cutting plan
4. Model control
5. Preparation of control map and dimensional tolerance
6. Design of construction and control fixture
7. Construction of construction and control fixtures
8. Programming and modifying the program
9. Cutting
10. Preparing the block with a milling machine
11. UT test
12. Prototype construction
13. Production
14. Cutting and size of the blade root
15. Dimensional control
16. Coding
17. Polishing
18. MT test
19. Pinning shot
20. Arranging the rows



➤ Steam Turbine Rim and Blade

◆ TABA Engineering & Services (IFA SANAT TABA) Co.

www.tabaservice.com



Product Introduction:

The LP steam turbine is a type of electricity generation turbine that generates electricity at a relatively lower cost than some other technologies and includes 10 rows of fixed and moving blades in a left and right arrangement. Fixed-row rims and blades number 10 to 7, respectively, are the largest turbine rows. The fixed row blades change the direction of the moving fluid (here steam with high temperature) and change the temperature and pressure of the fluid according to the dimensions of the blades and the rim and the direction of the fluid movement

Founded:
2014

Application:

- * Increase in vapor pressure
- * Preventing the spiral movement of steam around the longitudinal axis by straightening the flow parallel to the longitudinal axis in steam turbines

This product is final B2B equipment.

Technical Specifications:

Blade row 10 (the largest V93.1 steam turbine stator blade)	<ul style="list-style-type: none"> * Dimensions: 140 × 140 × 600 mm * Material: Gray cast iron with ferrite-pearlite background with spherical graphite, grade GGG45
Blade row 9	<ul style="list-style-type: none"> * Dimensions: 490 × 80 × 60 mm * Material: Gray cast iron with ferrite-pearlite background with spherical graphite, grade GGG45
Blade row 8	<ul style="list-style-type: none"> * Dimensions: 394 × 56 × 40 mm * Material: Martensitic stainless steel, grade X22CrMo V12.1
Blade row 7	<ul style="list-style-type: none"> * Dimensions: 350 × 57 × 40 mm * Material: Martensitic stainless steel, grade X22CrMo V12.1

International Standards or Permissions:

- * DIN EN 10204
- * DIN EN 10269
- * ISO 9934-1
- * ISO 2768

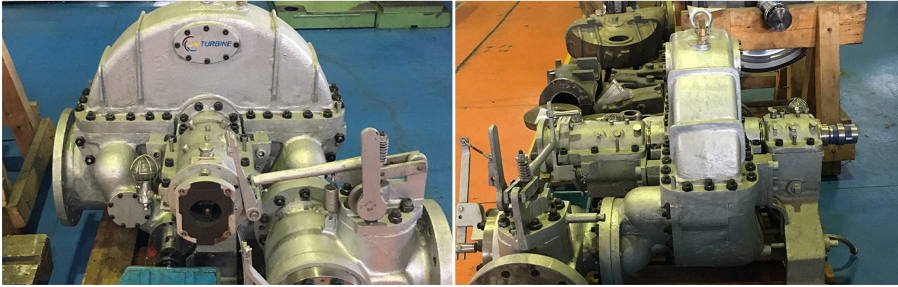

➤ Complete Package of Single-Stage Impulse Steam Turbines Up to 1.1 MW

◆ Wira Turbomachinery Co.

www.wiratehran.com



Product Introduction:

Steam turbine is one of the most widely used drives to drive various equipment such as pumps, compressors, fans and other turbomachinery equipment that require driving force. Wira company is a manufacturer of steam turbines that are widely used and in accordance with API and non-API standards. In fact, in order to build an efficient and reliable steam turbine with a flexible design option to respond to different energy and steam consumption conditions, this company designs and manufactures UNI-TURBINE according to the customer's needs.

The exclusive software of this company, prepared by MATLAB software, calculates thermodynamic characteristics and general dimensional specifications, and after analysis and optimization by ANSYS CFX software and modeling in CATIA and SOLIDWORKS software, construction drawings are prepared. Wira's single-stage steam turbine is designed and manufactured in five sizes and different options to adapt to the existing steam conditions and intended use up to 3500 horsepower (2600 kW).

Founded:

2000

Application:

Operators of pumps, fans, compressors, generators, etc. in industries such as oil and gas, petrochemical, chemical, steel, paper, sugar, food, pharmaceutical, marine, edible oils, etc.

This product is final B2B equipment.

Technical Specifications:

Service Range	7Hp (50 kw) to 3500 HP (2600 kw)
Maximum rotation speed	4500 rpm
Maximum input pressure	48 bar (700 psi)
Maximum input temperature	400 °C (752 °F)

Advantages:

- ✧ Economically affordable by increasing the efficiency of the energy cycle
- ✧ Simple and low-cost maintenance and repair
- ✧ Installation support
- ✧ 2 year warranty
- ✧ 10 year after-sales service

International Standards or Permissions:

API 611

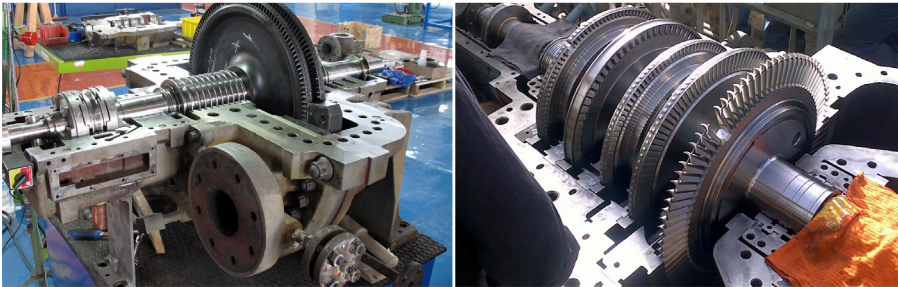

► Repair and Reconstruction of the Integrated Rotor (Forged) of the Steam Turbine

◆ Wira Turbomachinery Co.

www.wiratehran.com



Product Introduction:

During service, steam turbine rotors are always exposed to damage caused by thermal cracks, oxidation, hot corrosion, erosion, impact of foreign particles, wear and fatigue cracks. In case the rotor disc of a turbine is severely damaged, two solutions are suggested by the original manufacturers (OEM):

1. Removing the damaged disc completely and operating the turbine at a lower efficiency
2. Buying a new rotor (new rotor will be delivered in at least two years)

Replacing a damaged disc with a new one requires spending a lot of money on the one hand, and on the other hand, regarding the turbine rotors with an integrated (forged) disc axis, it is practically impossible to replace the disc, and cracks occur at sensitive points such as the balance holes on the disc, blade root groove, or in the disc-to-shaft connection area can render an expensive rotor unusable. In this situation, the only possible option is to remove the damaged disc completely and operate the turbine with lower efficiency. In the current service, as a third solution that few companies in the world offer, removing the damaged disc and creating a new disc directly on the axis using the combined technology of local SAW and PWHT is on the agenda.

Founded:

2000

Application:

Operators of pumps, fans, compressors, generators, etc. in industries such as oil and gas, petrochemical, chemical, steel, paper, sugar, food, pharmaceutical, marine, edible oils, etc.

This product is final B2B service.

Technical Specifications:

Repair steps:

1. API687- first phase inspection
2. API687- phase II inspection
3. Blade root design, optimization and preparation
4. Redesigning blades and making them
5. Designing and carrying out the operation of making a disk (build up)
6. Assembly operation of blades on the disk
7. Rotor dynamic balance
8. Final inspection

International Standards or Permissions:

API 687

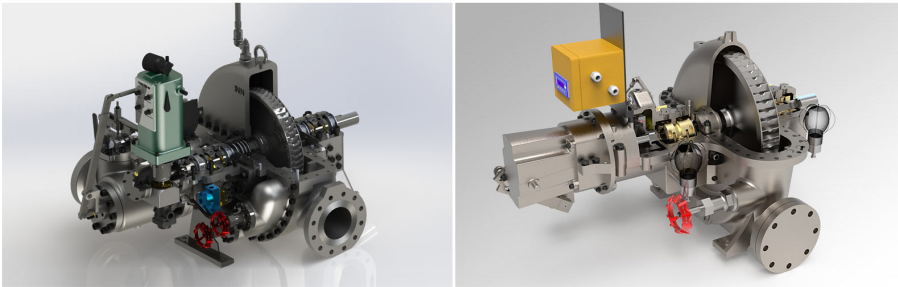

➤ Package of Single-stage Impulse Steam Turbines with Power of Less Than 3MW

◆ Iran Nasb Niroo Co.

www.irnnco.com



Product Introduction:

In general, steam turbines are designed and manufactured in two types, back pressure and condenser, in terms of the type of application and working pressure. Back pressure turbines are used in small and medium powers in oil and industrial processes. In this type of turbine, after passing through the turbine and producing power, the steam is used as a source of heat production in oil and industrial processes such as heat exchangers, dryers, heaters and preheaters as well as direct injection which is used inside the process.

Founded:

1991

Application:

- * Driver in the pumps of refineries, petrochemicals and gas sites and combined cycle power plants
- * Driver in compressors of refineries, petrochemicals and gas sites and combined cycle power plants
- * Replacing electric motors in refineries, petrochemicals and gas sites and combined cycle power plants
- * Generator, fan and blower driver
- * Many applications in various industries such as CHP systems and turboexpanders
- * Application in wood and paper industries

This product is final B2B equipment.

Technical Specifications:

The main components of the turbine:

- * Disk
- * Blade
- * Ring nozzle
- * Shell
- * Control valve
- * Manual adjustment valve
- * Shaft
- * Bearings
- * Actuator

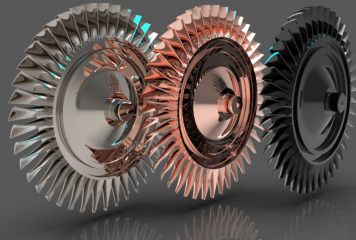

➤ Machining and Production of Various Parts of Water and Steam Turbines (Water Turbine Nozzle Rings, Steam Turbine Set Including Wheel, Casing, Shaft) and Impeller

◆ Pishro Sanat Daghigh Co.

www.psdiran.ir



Product Introduction:

Water turbine ring nozzle: The ring nozzle is one of the important components in water turbines that are used in power plants; This part is semi-circular and has holes at an angle and with a defined slope for injecting superheated water steam; Also, this part should be made by highly precise machining and in order to perform optimally and increase the efficiency of the turbine, it must be resistant to the environmental conditions of operation, i.e. corrosion caused by the fluid. The diameter of this part is directly related to the power of electricity production and the dimensions of the turbine. The angular machining process is very important and should be taken into consideration in making these parts.

Steam turbine set including Wheel, Casing, Shaft: A steam turbine has various parts, the main ones being Wheel, Casing and Shaft. Casing, Wheel and Shaft are in the form of casting, raw plate and fillet respectively. All parts are made using CNC lathe, 4 and 5-axis CNC milling machine.

Impeller: Impellers and fans with a special blade shape are used in rotating machinery, including blowers, compressors, turbochargers, and also fluid transfer propellers in pipes and channels. The shape, number and angle of the blades, in addition to having a direct effect on the performance of these parts, require complex machining methods and the use of special machine tools such as a 5-axis CNC milling machine.

Founded:

2006

Application:

- * **Water turbine ring nozzle:** Superheated water steam guiding nozzle in the housing of steam turbines in hydropower plants. Steam turbine set including Wheel, Casing, Shaft: Main parts used in steam turbine
- * **Impeller:** Used in rotating machinery, including blowers, compressors, turbochargers, and also propellers for fluid transmission in pipes and channels in various oil, gas, petrochemical, and aviation industries.

This product is final B2B equipment.

Technical Specifications:

Water turbine ring nozzle

- * **Material:** Special steels such as SS410
- * **Machining accuracy:** ± 0.01
- * Steam turbine set including Wheel, Casing, Shaft
- * **Material:** Ductile cast iron and special steel
- * **Main parts:**
 - * Shell (housing)
 - * Inner wheel
 - * Nozzle plate
 - * Main shaft or accessories
- * **Machining tolerance:** ± 0.02

Impeller

- * **Material:** Ranging from 6000 series aluminum to super alloys that can be used in aircraft engines
- * **Machining process:** CNC lathe and 4,3 and 5 axis milling machines

Advantages:

- Avoid assembly errors

International Standards or Permissions:

DIN 7168-F

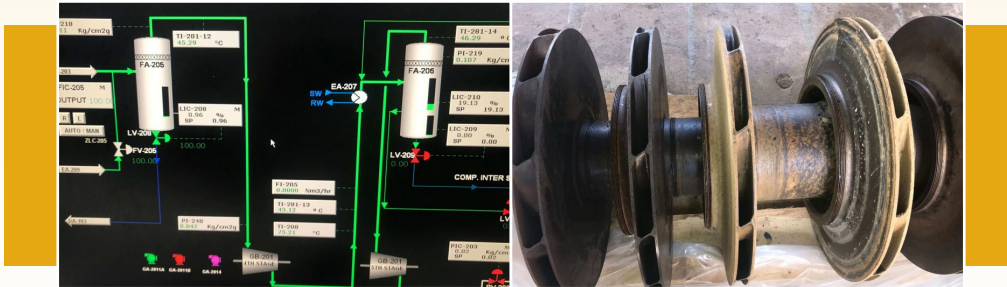

► Online Performance Analysis of Process Turbocompressors (Steam Turbine-Centrifugal Compressor) of Petrochemical Units

◆ PHIDCO Co.

www.phid-co.com



Product Introduction:

In sensitive rotating process equipment such as turbocompressors, it is not possible to understand the internal condition by simply monitoring vibrations, oil, sound and thermography; In other words, in some cases, despite one of these items or all of them getting out of range, it is not possible to identify the main problem of the equipment for stopping and repairing (especially when several compressors are connected to a steam turbine, it is not possible to figure out which of the pieces of equipment causes the mechanical problem for stopping and overhauling). Sometimes none of the parameters are out of range, but there is a process problem. For instance, it is very difficult or even impossible to find out whether the surface of the blades of a steam turbine has been crusted and dusty, or the loss of internal sealing in a working turbine and compressor, etc., just by using the monitoring method. In these cases, online performance analysis technique can be used for the equipment in service as a complement to the care and maintenance systems in rotating machines.

Application:

Investigating and specifying the internal conditions of the turbine, compressors, condenser and also their process conditions

This product is final B2B service.

Technical Specifications:

The description of this service is as follows:

- * Checking and studying the manufacturer's technical documents Field investigation to learn more about the operating conditions and the existing process of the turbocompressor and auxiliary systems
- * Necessary calculations based on the information obtained from the field test in order to analyze the internal situation and also the actual operating point in order to achieve the accuracy of the calibration of the instrumentation.
- * Providing the required reports in case the instruments are not calibrated
- * Performing the necessary calculations to check the presence of additional loads on the turbine and compressor
- * Necessary calculations to check and analyze condenser and ejector systems
- * Investigating and analyzing the root cause of the absence of required vacuum in the condenser
- * Performing the necessary calculations to obtain the actual performance conditions
- * Providing a comprehensive report on the performance of the turbocompressor and the results obtained from the analysis and calculations.
- * Providing suggestions and solutions to solve the existing problems and increase the reliability of the equipment

Advantages:

- * Reducing depreciation and the cost of repairing the machines
- * Timely repairs and reduction of stops
- * Increasing production

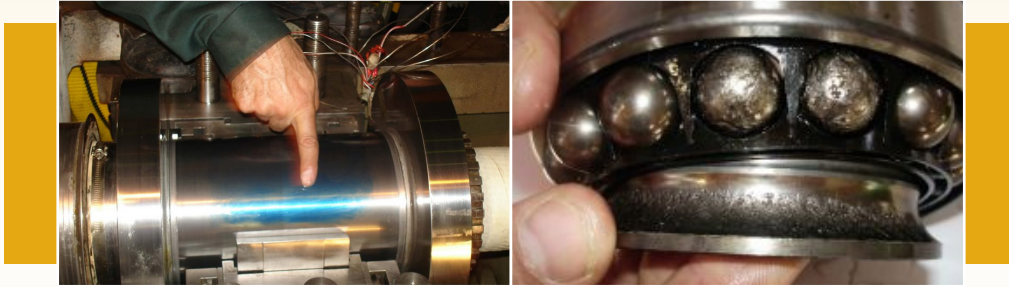

➤ Inspection and Failure Analysis of Process Turbocompressors (Steam Turbine-Centrifugal Compressor) of Petrochemical Units

◆ PHIDCO Co.

www.phid-co.com



Product Introduction:

Regarding the sensitive rotating process equipment such as turbocompressors, frequent problems sometimes arise in line with the capacity development plan or the wrong use of the equipment, which can only be solved with a detailed understanding of the process, equipment and how they work. Solved the problems. In fact, equipment failure analysis is done using monitored data and the use of manufacturer's documentation and PFD design, as well as checking the history of repairs.

Application:

Investigating and specifying the internal conditions of the turbine, compressors, condenser and also their process conditions

This product is final B2B service.

Technical Specifications:

The description of this service is as follows:

- * Checking and studying the manufacturer's technical documents
- * Field investigation to learn more about the operating conditions and the existing process of the turbocompressor and auxiliary systems
- * Inspection of instrumentation and control system of the plant
- * Investigation and analysis to find the root of the problems announced by the employer
- * Providing a comprehensive report on the performance of the turbocompressor and the results obtained from the analysis and calculations.
- * Providing suggestions and solutions to solve the existing problems and increase the reliability of the equipment

Advantages:

- * Reducing depreciation and the cost of repairing the machines
- * Timely repairs and reduction of stops
- * Increasing production



➤ Wind Turbine Cast Iron Parts (Intermediate Housing, Main Shaft Coupling)

◆ Ghaltak Sazan Sepahan Co.

www.ghaltaksazan.com



Product Introduction:

A wind turbine is used to convert the kinetic energy of the wind into mechanical energy. The components of this turbine include Intermediate Housing and Main Shaft Coupling; and the main equipment of the turbine body is installed on these parts. These parts are among the fixed and non-consumable and non-replaceable parts of the 2.5 MW wind turbine, which due to their role and the need to bear loads from different directions caused by wind force, ductile cast iron EN-GJS 400 18U-LT (GGG 40.3) has been chosen.

Main Export Destinations:

UAE, Afghanistan

Export History:

Between 10,000,000 - 50,000,000 \$

Founded:

2006

Application:

Converting wind kinetic energy into mechanical energy

This product is final B2B equipment.

Technical Specifications:

Yield strength	About 220 mPa
Impact energy	7-12 J
Elongation	About 12 %

Advantages:

- * Large dimensions of the piece
- * Quality and dimensional accuracy
- * Maintaining strength at temperatures below twenty degrees Celsius
- * Suitable malleability

International Standards or Permissions:

- * BS EN 12680-3 Level 1
- * BS EN 1369



➤ Wind Turbine Tower

◆ Sepahan Mapna Engineering & Equipment Manufacturing Co.

www.mapnasts.ir



Product Introduction:

In wind turbines, the kinetic energy of the wind is converted into mechanical energy and then into electrical energy. Wind turbines can be combined with solar cells (photovoltaics) for optimal use and production of more power. Currently, the largest capacity of wind turbines installed in the past few decades has been of the type connected to the grid. The working steps of a turbine are completely opposite to the working steps of a fan. In the fan, electrical energy is converted into mechanical energy and causes the blade to rotate. In the turbine, the wind hits the blades and turns them. The rotation of the blades causes the rotation of the main axis. This axis is connected to an electric generator.

Currently, the task of building wind turbine towers in Mapna Group has been assigned to Sepahan Mapna Engineering and Equipment Manufacturing Company. This company is currently the only manufacturer of wind turbine towers with production capacity in the range of megawatt capacity in Iran.

Founded:

1996

Application:

Converting wind kinetic energy into mechanical energy and then into electrical energy

This product is final B2B equipment.

Technical Specifications:

Weight	210 tons
Material	Carbon steel
Height	85 meters consisting of 5 segments

Advantages:

- * Not needing a lot of land for installation
- * No environmental pollution
- * Lower current costs and long-term wind energy investment costs



► Construction of KW 660 Wind Turbine Asynchronous Generator

◆ Fan Generator Co.

www.fangenerator.com



Product Introduction:

Generators are machines that convert mechanical energy into electrical energy. Electric generator or generator is a machine that converts mechanical energy into electrical energy through electromagnetic induction. The source of mechanical energy may be a steam turbine, a water turbine, a wind turbine, or an internal combustion engine.

The use of environmentally compatible energies, including wind energy, has received much attention in most of the industrialized countries of the world and has a growing trend. In parallel with the development of technology in order to preserve non-renewable sources of fossil fuels and reduce environmental pollution, Fan Generator Industrial Group has paid attention to the use of new energies. In this regard, in 2002, this industrial group, in cooperation and based on the technology of the German Weier Electric company, started the joint construction of 660KW/690V/4-P asynchronous generators for installation in wind turbines. This industrial group built this type of generator 100% domestically in 2009, and even now, the generators produced by this industrial group are in service in Iran's wind farms.

Founded:

1984

Application:

Providing electrical energy to residential, commercial, industrial or agricultural units

This product is final B2B equipment.

Technical Specifications:

Power	660 kW
Voltage	690 V
Current range	607 Amp
Power factor	0.91
Weight	3200 kg

Advantages:

- * Having high mechanical strength and no need for short-term maintenance and repair operations
- * No need to install slip rings and brushes
- * The ability to increase the sliding speed in the steady state of the system in order to prevent electromechanical oscillations by increasing the resistance of the rotor.
- * The smoothness of the sinusoidal waveform of the output voltage of the generator and the absence of harmonics therein



➤ 5 kW Vertical Axis Wind Turbine

🏠 Wind Max Co.

www.windmax.ir



Product Introduction:

Considering the fossil fuel reduction crisis and global warming concerns, renewable energy sources are a sustainable solution to meet society's energy needs. Wind energy is considered as one of the most important sources of renewable energy. In recent years, small-scale wind turbines (100 W to 100 kW) as serious helpers for powering homes, farms, small businesses, and also energy providers for the electrical grid have emerged.

This product is an example of the family of small size wind turbines. A wind turbine is a system that converts the kinetic energy of the wind into electrical energy. These types of wind turbines are classified based on various criteria such as the amount of power produced, the arrangement and placement of the blades, and their type of use of wind power.

Founded:

2015

Application:

- * Electricity generation for urban and rural areas
- * Electricity generation along highways
- * Construction of wind power plants onshore and offshore
- * Supplying electricity to border areas and far from the electrical grid
- * Off-grid electricity storage

This product is final B2B equipment.

Technical Specifications:

Height	* Blade: 3m * Base: 9m
Material of the blade	Composite
Generator	PMSG
Input	Metal shaft connected to blades with a range of 20 to 350 rpm

Advantages:

- * High starting torque
- * No dependence on wind direction
- * It has a very elegant and beautiful appearance compared to conventional blades



➤ Simulator of Wind Turbine's Behavior Based on Doubly-Fed Induction Generator

◆ Viana Industrial Electronic Technologists Co.
www.vietgreenenergy.com



Product Introduction:

This product consists of a cage rotor induction motor as a wind turbine and a wound- rotor induction motor as a doubly-fed induction generator. In this product, all converters and control systems used in both turbine and generator parts are made by Diyari company. Therefore, a high flexibility for any changes and customization will be possible. This system is designed to carry out research on doubly-fed induction generators connected to wind turbines, and it is capable of generating power in both network-connected and disconnected modes.

Application:

- ※ Academic centers to analyze and review the ideas of professors and students
- ※ Scientific and educational centers for research and development
- ※ Conducting various tests to check and compile the grade of desired network codes

This product is final B2B equipment.

Technical Specifications:

- ※ Existence of protection systems to prevent laboratory errors and mistakes
- ※ Tolerating shock currents up to 6 times the rated value
- ※ The existence of two separate control systems and as a result, the ability to control the system with online (realtime) and offline (DSP28335) card controllers
- ※ Ability to change the wind speed from zero to 15 times the rated speed
- ※ The ability to apply all types of single-phase and three-phase errors to check the LVRT of the doubly-fed induction generator

Advantages:

- ※ Ability to run simulation directly from Simulink environment of MATLAB software
- ※ Very easy to use

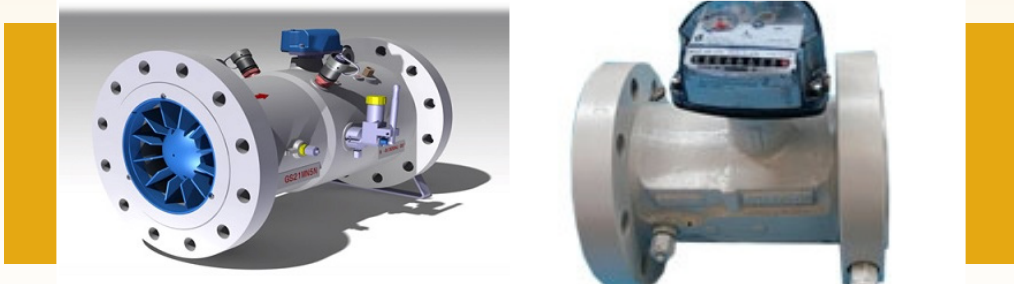

Application:

Measuring the amount of gas consumption in places such as large industries, pressure reduction stations and intercity metering stations and city entrances.

➤ **2-25 Inch Turbine Gas Meter**

◆ Gas Souzan Industrial & Manufacturer Co.

www.gas-souzan.com



Product Introduction:

Turbine meters that are used to measure gas consumption in places such as large industries, pressure reduction stations and intercity metering stations and city entrances (places with high consumption and high pressure) are designed and produced in three classes 150 (with pressure tolerance up to 20 bar), 300 (with pressure tolerance up to 50 bar) and 600 (with pressure tolerance up to 110 bar) and in sizes 2, 3, 4, 6, 8, 10, 12 And 25 (rarely) inches. The gas entering the meter hits the blades of the turbine and causes it to rotate (the axis of the turbine is along the path of the fluid flow); This rotation is transferred to a magnetic plate placed next to the turbine body through the axis and the worm gear. On the other hand, the counter mechanism counts the number of revolutions of the magnetic plate with a magnetic plate placed outside the turbine body. Considering that the rotating speed of the turbine is proportional to the linear speed of the gas, the volume of passing gas will be calculated by calculating the number of revolutions of the magnetic plate and knowing the dimensions and size of the turbine.

Main Export Destinations:

Russia, Netherlands, Georgia, Kazakhstan, Turkmenistan, Armenia, Azerbaijan, Belarus and Ukraine

Export History:

between 500,000 - 1,000,000 \$

Founded:

1980

This product is final B2B equipment.

Technical Specifications:

Body material	<ul style="list-style-type: none"> * For sizes 8 inches and under (for all classes) and for 10- inch diameter (class 150): cast steel A216WCC * For 10 inch diameter class 300 and 600 and larger diameters: A105 steel forged pipe
Propeller material	Aluminum alloy 6018
Magnetic couple material	Magnetic steel 318L

Advantages:

Measurement of gas passing through transmission lines up to 25 inches and pressure up to 110 bar



➤ A Set of Hot Parts and Fixed and Moving Blades of the GT13 Turbine

◆ Mapna Turbine Blade Engineering and Manufacturing (PARTO) Co.
www.mapnablade.com



Product Introduction:

This turbine has 5 rows of moving and fixed blades in its hot section, and its combustion system is also of the Annular type.

Technical Specifications:

- * **Blade material:** Nickel based superalloys
- * **Manufacture technology:** Equiaxed

This product is final B2B equipment.

Main Export Destinations:

Turkey

Export History:

Up to 500,000 \$

Founded:

2000

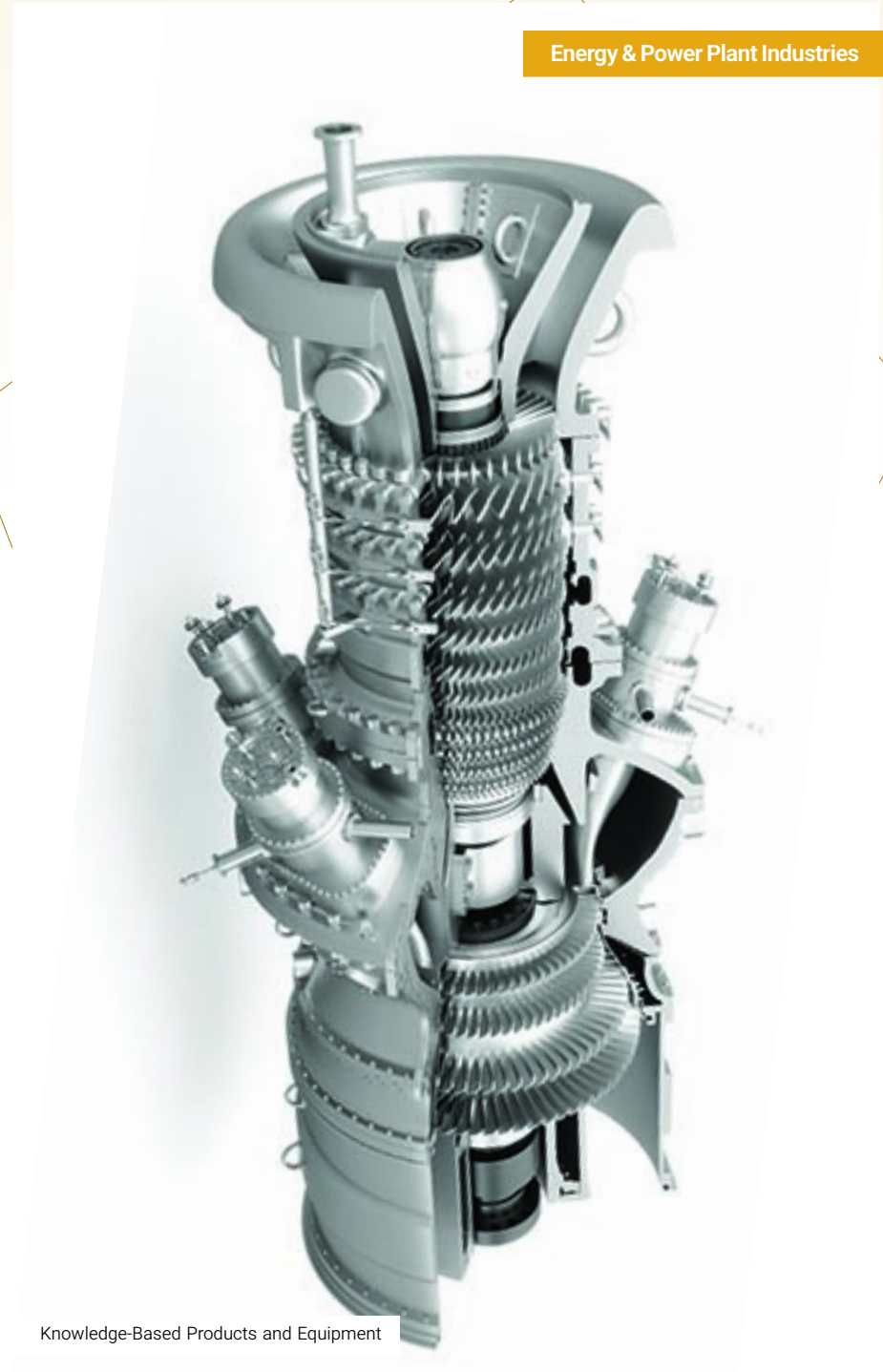

Knowledge-Based Products and Equipment

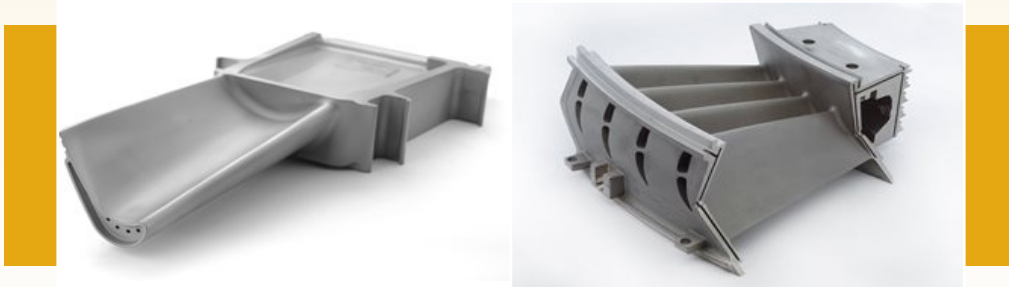

➤ Fixed And Moving Blades of GE-F9 Turbine

- ◆ Mapna Turbine Blade Engineering and Manufacturing (PARTO) Co.
www.mapnablade.com



Product Introduction:

GE-F9 turbine is one of the important turbines in thermal power plants in the country. This SINGLE SHAFT turbine has a CAN ANNULAR type combustion system and has a nominal capacity of 123 MW in open cycle and ISO conditions and has three rows of fixed and moving blades in the hot section.

Technical Specifications:

- * **Blade material:** Nickel based superalloys
- * **Manufacture technology:** Equiaxed

This product is final B2B equipment.

Main Export Destinations:

Turkey

Export History:

Up to 500,000 \$

Founded:

2000

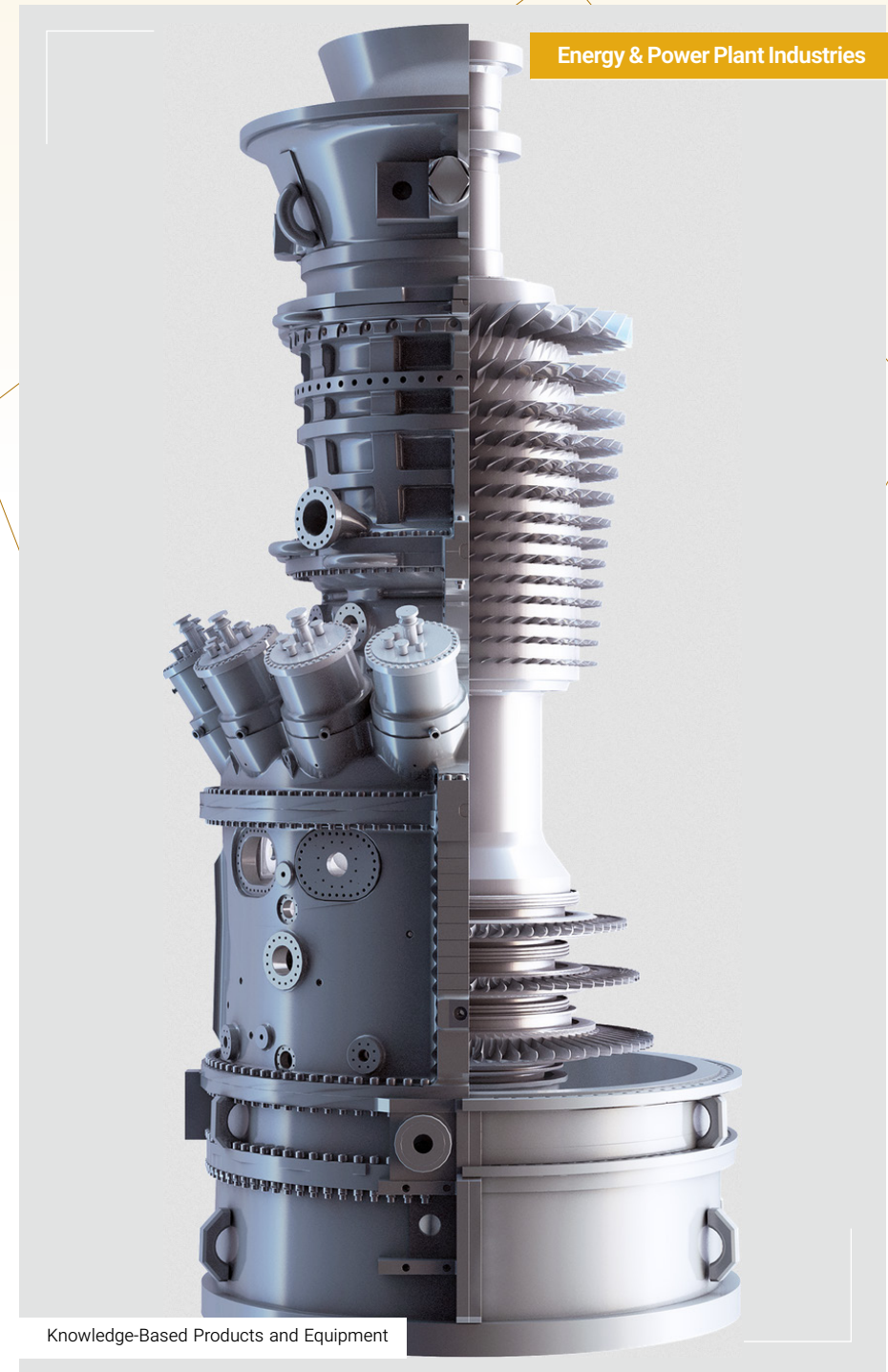



➤ Frequency Converter for Starting Gas Power Plants (SFC)

- ◆ Mapna Electric & Control Engineering & Manufacturing (MECO) Co.

www.mapnaec.com



Product Introduction:

Synchronous generators related to gas power plants can be started in two ways and reach the rated speed:

1. Using the initial startup engine
2. Use of static frequency converter (SFC)

Using the SFC method has many advantages over the startup engine method, and this method is used in many power plants. However, due to the limitations of SFC (generally due to thermal conditions), the number of startups that can be considered for each SFC device is limited.

Application:

In the gas refinery and gas transmission lines

This product is final B2B equipment.

Founded:

2004



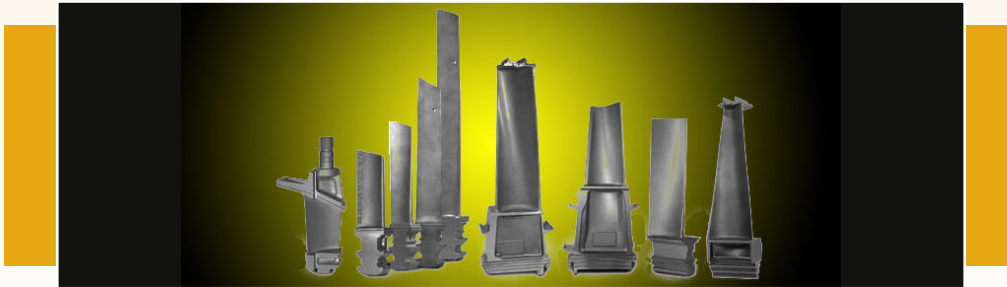

► Reconstruction and Repairs of Hot Section Blades, Combustion Chamber and Turbine Liner

◆ MavadKaran Engineering Co.

www.mavadkaran.com



Product Introduction:

When the blade or other parts used in the hot parts of the turbine are exposed to high temperature for a long time, various damages can occur to them. Damages may be physical or related to microstructure; Therefore, with the passage of time, the piece loses its initial efficiency. The repair of gas turbine parts takes place in different stages, during which the metallurgical and dimensional properties of the parts are restored. In general, the moving and fixed components of the gas turbine suffer from the following damages:

- * **External physical damage:** External damage includes fatigue cracks, surface oxidation and corrosion, FOD and abrasion.
- * **Internal microstructural damage:** Internal microstructural damage also includes the dissolution of carbides at the grain boundary, change in the gamma prime phase, change in grain size, and the structure of the nickel-based superalloy, which can be solved by rejuvenating heat treatment.
- * **Dimensional defect:** Any dimensional defect that occurs on the blades over time is called a dimensional defect.

Main Export Destinations:

Italy, Turkey

Export History:

Between 500,000 - 1,000,000 \$

Founded:

1996

Application:

Power plant industries

This product is final B2B service.

Technical Specifications:

The repair and restoration of blades is carried out by performing the following processes:

- * **Cleaning:** Cleaning is usually done before inspection and before and after repair and restoration operations.
- * **Decoating:** A large amount of coating is removed by a chemical process.
- * **Rejuvenation heat treatment:** By working the part at high temperature, the dimensions and shapes of gamma prime deposits will change and also a brittle layer of carbides will be created along the grain boundary, which will reduce toughness and creep resistance.



Application:

Air purification systems of gas turbines equipped with pulse cleaning system

➤ **Power Plant Air Filter with Nanofiber Technology**

◆ **Behran Filter Co.**

www.bهرانfilter.com



Product Introduction:

The air filter is used to protect the power plant equipment parts from damage by dust particles, contamination and other harmful particles in the air. This product is coated with the nano surface technique of cellulose or synthetic fibers (usually with a diameter of 10 to 30 micrometers) with a layer of nano fibers, usually with a diameter of 50 to 400 nm) by electrospinning. There are two different ways to separate the particles in the structure of the filter paper, and we achieve the second method by using nano technology:

- * Volume filtration in which particles are separated, depending on their size, in different layers of filter paper.
- * Surface filtration in which all particles are separated on the surface of the filter paper.

In Behran Filter company, the used filter paper is coated with a layer of polymer fibers (made of polyamide) with a diameter of less than 100 nm using an electrospinning machine before the folding and pleating operation.

Main Export Destinations:

Iraq

Export History:

Up to 500,000 \$

Founded:

1992

This product is final B2B equipment.

Technical Specifications:

Sample	Average filtration efficiency
Blank filter	70%
Nanofilter	96%

Advantages:

- * Increasing filter life by using surface filtration
- * Efficiency higher than %95 for -400nm particles in the separation of airborne pollution particles
- * Lower price compared to similar products

International Standards or Permissions:

EN 779



➤ Industrial Air Filters Containing Media Modified with Polymer Nanofibers

◆ Azad Filter Co.

www.azadfilter.ir



Product Introduction:

Nanofibers with less thickness and higher specific surface area than normal fibers have many applications in filtration, and electrospinning is one of the important and effective processes in the production of continuous nanofibers from synthetic and natural polymers. To improve the performance and efficiency of the filter, electrospinning fibers are used. This technology, while increasing the efficiency of dust absorption, does not cause a large pressure drop. The electrospun fibers have a diameter of less than 100 nm and cover the surface of the filter paper uniformly.

Main Export Destinations:

Iraq

Export History:

Up to 500,000 \$

Founded:

1995

Application:

Air inlet of turbines, compressors, locomotives and...

This product is final B2B equipment.

Technical Specifications:

Contains electrospun polymer nanofibers

Advantages:

Ability to remove dust with high efficiency

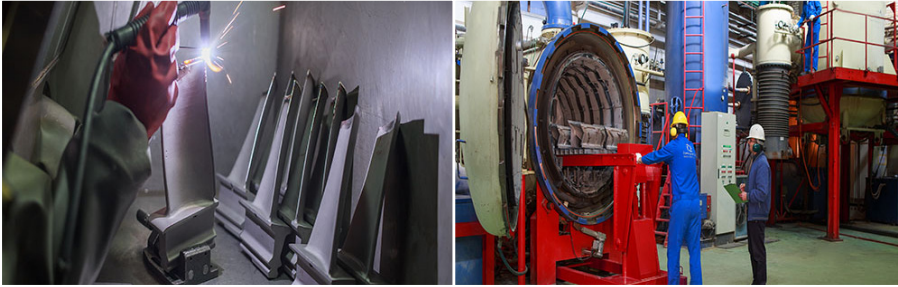

► Engineering Services for Failure Analysis and Turbine Blade Life Estimation

◆ Shahriar Turbine Components Co.

www.sh-turbine.com



Product Introduction:

In high duty industrial equipment such as turbines and compressors, parts that have a long lifespan are used. Based on the design, after spending a certain lifetime by these parts, it is necessary to repair and restore them. Usually, after one or two restorations, the parts have a high risk in terms of functionality, and they are often used in special conditions. In many cases, parts fail or fracture before the expected time. In these cases, it is necessary to find out the reasons for the defects to prevent the repetition of these defects. In all types of machines, depending on the type of defect, different analyzes are needed to find out the reason for the failure of parts or defects. Sometimes, design problems, stability problems such as lack of balance, operation problems such as changes in input material, operating conditions under load, and defects during the production of parts cause major problems for the parts in the mentioned applications. In equipment such as turbines, due to the very high speed and power of the machine, if a defect occurs in one part, sometimes very destructive results occur on other parts, which makes finding the main reason of the failure as complicated as a puzzle.

This product is final B2B service.

Founded:

2000

Energy & Power Plant Industries



Knowledge-Based Products and Equipment



➤ Parts and Overhaul of the Rotor of Steam Turbines with Power of Less than 20 MW

◆ TurbineMachine m.e.Parts Supplier Co.

www.turbinemachineparts.com



Product Introduction:

A steam turbine is a turbo machine that takes thermal energy from pressurized steam and uses it to perform mechanical work by means of a rotating shaft. This machine owes much of its thermodynamic efficiency improvement to the use of multiple stages of steam expansion because this situation is close to the reversible ideal expansion process. Steam turbines are produced in different capacities from 0.75 kW to 1500 MW units and have various applications ranging from driving pumps and compressors to generating electricity.

Application:

- ✧ Pump and compressor drive
- ✧ Generating electricity

This product is final B2B equipment.

Founded:

2011





➤ **Turbine Hot Parts Including** (IGT25-SEGMENT STAGE1, IGT25-SEGMENT STAGE2, IGT25-SEALING CASTING)

◆ **Pars Investment Casting Co.**

www.parscasting.com



Product Introduction:

Turbine hot parts such as shroud segments and vanes are parts that are less complicated compared to blades and are produced using precision casting process. These parts are mainly made of superalloys. The production process of turbine’s hot chamber parts is simpler than blades. These parts mostly have a very simple shape and therefore do not require a core making stage in the production process. The making process of the blades for these parts is similar and most of them do not need any ceramic cores. After casting, these parts are sandblasted and transported outside the company for heat treatment. In terms of technology, these parts are classified as high-tech products; Moreover, in terms of casting, compared to blades, they have lower technology.

Main Export Destinations:

England

Export History:

Up to 500,000 \$

Founded:

2009

Application:

- ※ Fluid transfer in power plant, oil and gas industries
- ※ Fuel supply for power plant turbines

This product is final B2B equipment.

Technical Specifications:

Alloy	Stainless steel 1.4408 Hastelloy X nickel-based super alloy
Service temperature of the piece	From 400 to 700 degrees Celsius
Periodic visit	20000 hours

Advantages:

- ※ Moving large pumps inside oil and gas pipelines
- ※ Providing the energy required by factories and special areas apart from the network
- ※ Power generation of nationwide networks in the electricity industry



➤ Reconstruction and Repair of Hot Turbine Parts Fixed and Moving Blades, Liners, Nozzles and Combustion Chambers

◆ Pars Atlas Turbine Co.

www.atlasturbine.com



Product Introduction:

Gas turbines have expensive and complex parts in their hot part, which are subject to various damages during operation, such as cracks, burns, wear and tear, or impact of a foreign object, rupture, etc. and they should be replaced with either new or repaired and rebuilt parts; Therefore, due to the high price of parts, one of the economic methods is to rebuild it based on technical and engineering principles and standards.

Founded:

2003

Application:

Reconstruction of gas turbine parts

This product is final B2B service.

Technical Specifications:

Usually, there is a special and common procedure to reconstruct each part. At the beginning of the entry of the parts to the reconstruction section, an external inspection of the parts is done and a report of the defects and the scrap parts is prepared; Then, to remove the coating, the piece must be sandblasted with completely round zirconia or aluminum balls (depending on the material and type of coating) of the same size. Finally, all parts of the part are examined using dimensional and visual inspection methods and then checked by penetrating liquid and ultrasonic inspection.

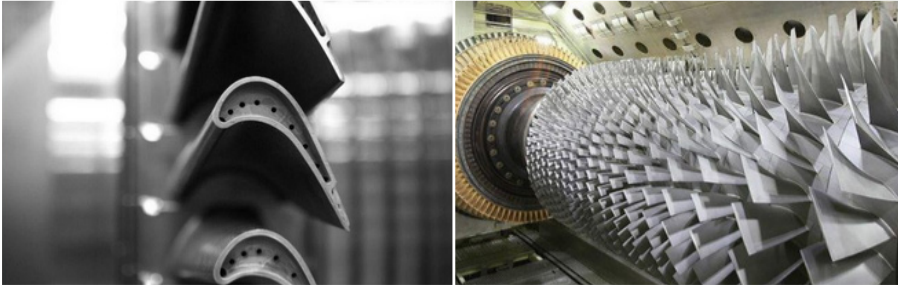

➤ APS and HVOF Coating Services for Turbine Parts

◆ Pars Atlas Turbine Co.

www.atlasturbine.com



Product Introduction:

Coating turbine parts, especially hot parts, is very important due to exposure to high temperature, thermal and mechanical stresses, as well as highly corrosive environment and hot oxidation and corrosion phenomena. In general, these coatings consist of two sections: the bondcoat section and the topcoat section. Applying these two types of coating on the hot parts of gas turbines is done by atmospheric-plasma spraying (ASP: Air Plasma Spray) and high-velocity oxygen-fuel spraying (HVOF: High Velocity Oxy Fuel). Atmospheric plasma spraying (APS) is generally used for coating ceramic materials or cermet compounds that have a high melting point; In this method, due to the extremely high temperature of the plasma flame (about 30,000 degrees Celsius) and the gas pressure, the necessary conditions are provided for melting the refractory particles and throwing them at a high speed towards the surface of the piece. But in the HVOF process, a combination of oxygen with different types of fuels such as hydrogen, propane and kerosene is used. Fuel and oxygen are mixed together in a certain ratio and come out of the mouth of the gun with high pressure and speed after combustion.

Application:

Creating resistance to wear and corrosion in wellhead equipment

This product is final B2B service.

Founded:

2003

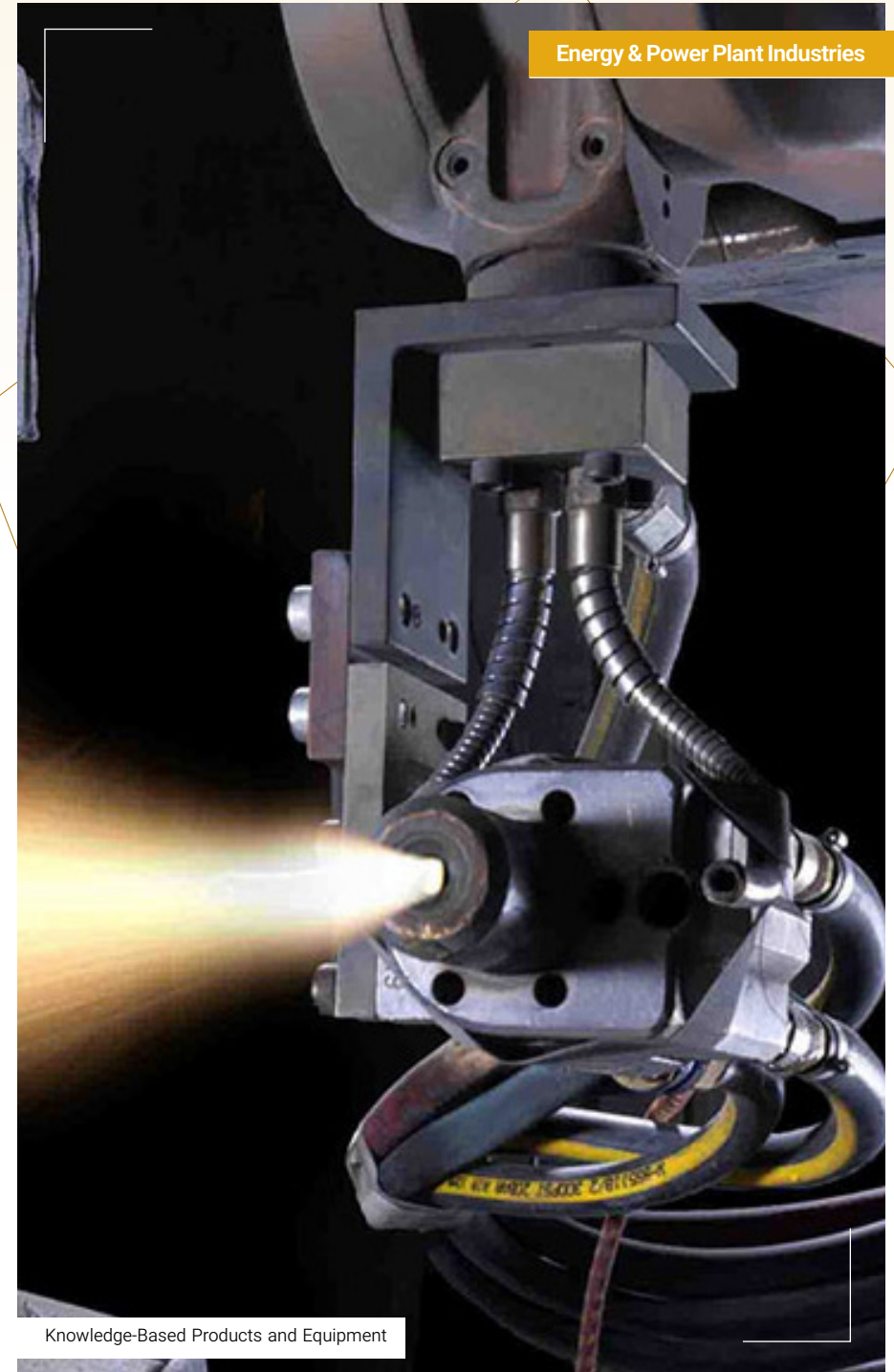

**Application:**

Gas turbine rotor repair

➤ Assembly of the Rotors of GEF5 and GEF6 Turbines

◆ Pars Atlas Turbine Co.

www.atlasturbine.com

**Product Introduction:**

According to the manufacturer's instructions, the rotor of gas turbines must be repaired and renewed at some stages of operation; For this purpose, all parts of the rotor are taken apart and undergo detailed inspections, the old parts are replaced with new parts, the rotor is assembled and by performing the balancing operation, it is again prepared for a working period.

Founded:

2003

This product is final B2B service.

Technical Specifications:

In general, the parts in the turbine are arranged as follows:

1. First, depending on the manufacturer's design, the moving blades are installed on the turbine discs after design and construction.
2. After the blades are fixed on the discs, these discs must be connected together to form the rotor compressor; This connection is made by three methods: penetration welding, EBW and the use of TIE BOLT TIE ROD.
3. Next, the rotor is generally balanced and the required crack of the central BOLT of the rotor is made based on the crack meter.



➤ Power Transmission Gearbox from Turbine to Compressor PHILADELPHIA 206

◆ Alborz Turbo Compressor Co.

www.alborztc.com



Product Introduction:

A power transmission gearbox is a device that is used to transfer mechanical power from a power generation source to a consumer and also provide the torque and rotational speed required by the consumer. Also, the direction of torque transfer can be changed with a gearbox.

Application:

Power transmission from gas turbine to centrifugal compressors

This product is final B2B equipment.

Technical Specifications:

Gearbox power	4000 hp
Input speed of gearbox	15700 rpm
Output speed of gearbox	22543 rpm

Founded:

2010



Knowledge-Based Products and Equipment

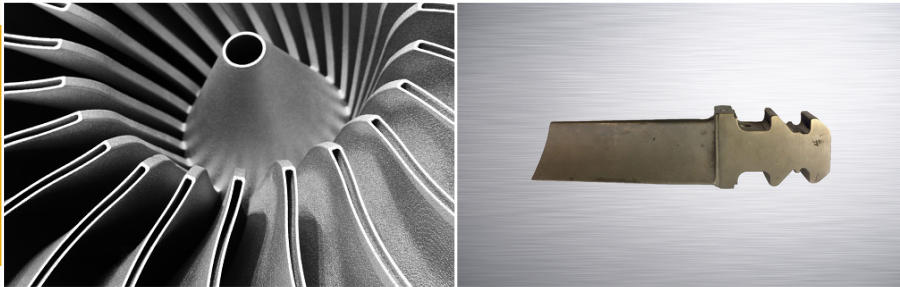

➤ Rejuvenation and Repair of Turbine Blades, BLADE CAREER, Hot Section

◆ Faradid Turbo Sanat (FTS) Co.

www.turbosanat.com



Product Introduction:

When a gas turbine blade is working at a high temperature, various damages can occur to it. These damages may be physical or related to the microstructure; Therefore, with the passage of time, the part loses its initial efficiency. The repair of gas turbine parts takes place in different stages, during which the metallurgical and dimensional properties of the parts are restored. In general, the moving and fixed components of the gas turbine suffer from the following damages:

- ※ **External physical damage:** External damage includes fatigue cracks, surface oxidation and corrosion, FOD and abrasion.
- ※ **Repair:** often involves grinding, welding and smoothing and sometimes brazing.
- ※ **Internal microstructural damage:** Internal microstructural damage also includes the dissolution of carbides at the grain boundary, change in the Γ' phase, change in grain size, and the structure of the nickel-based superalloy, which can be solved by rejuvenating heat treatment.
- ※ **Dimensional defects:** Any dimensional defects that develop on the blades over time.

This product is final B2B service.

Founded:

2013

Energy & Power Plant Industries



Knowledge-Based Products and Equipment

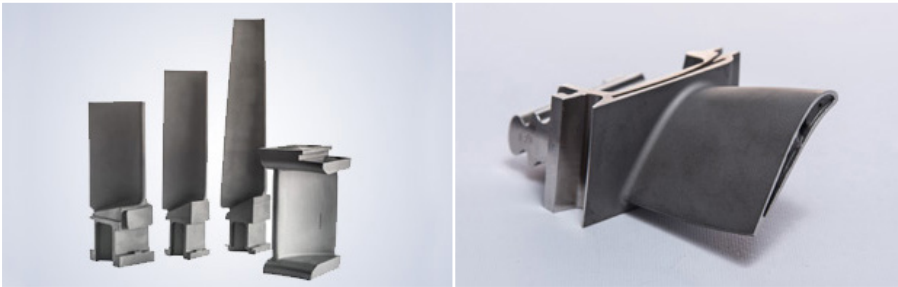

➤ **Other Advanced Turbine Parts (Compressor Blades - Hot Path Segments - Fuel Injection Nozzles - Turbine Consumable Parts)**

◆ **Badr Engineering Systems Co.**

www.badrsystem.com



Product Introduction:

Compressor blades: A gas turbine has one or more rows of fixed and moving blades in the compressor and turbine parts (compressor turbine or power turbine). Fixed and moving blades in different gas turbines have different designs.

Hot path segments: This part is one of the Hi-Tech parts used in the hot and cold paths of the gas turbine, which in terms of the used alloy material and dimensional designs are advanced parts and required by the power plant industry.

Application:

- ※ **Compressor blades:** Creating the incoming air flow for the turbine
- ※ **Hot path segments:** Creating a thermal shield to prevent thermal energy loss in the turbine

This product is final B2B equipment.

International Standards or Permissions:

- ISO 9001 ※
- ISO 14001 ※
- OHSAS 18001 ※

Founded:

1992





► Determination of Dynamic Parameters of Power Plant Components

◆ Lian Aryatash Saba (Aryatash) Co.

www.aryatash.ir



Product Introduction:

Dynamic designs of power plant components are done during a process. This is a process to determine the dynamic characteristics of rotating machines, including power plant turbogenerators, in which the dynamic parameters of the turbine and generator are estimated by conducting a series of specialized tests using special devices and performing advanced calculations. These parameters cannot be measured directly in normal mode, but in this method, by applying a series of inputs and taking certain outputs, transformation functions and dynamic parameters are estimated. These parameters are used for modeling rotating machines, observing machine behavior and adjusting controllers. The results of this type of project are important in conducting studies related to increasing the security and reliability of the country's electric power network.

Application:

- * Conducting dynamic studies by the power network management company
- * Making adjustments on power plant controllers

This product is final B2B service.

Founded:

2010





➤ **Twin & Triple Screw Pump Shaft and Mechanical Seal for Turbine Fuel | with a Maximum Working Pressure of 75 Bar**

◆ Arshia Co.

www.arshiaco.com



Product Introduction:

Screw pump is a rotary positive displacement pump. This pump consists of screws that mesh with each other and are rotating inside the cylinder or cylindrical cavity. The liquid enters from the suction side of the pump and moves directly along these mesh-shaped screws to the discharge line. The screw pump can work even if there is no fluid in the inlet; Therefore, no extra cost is needed to prevent the pump from drying out.

Founded:
2009

Application:

- ※ Fluid transfer in power plant, oil and gas industries
- ※ Fuel supply for power plant turbines

This product is final B2B equipment.

Technical Specifications:

Shaft revolution in rpm	1450 and 3000
Product performance	※ 130 and 200 kW for liquid fuel ※ 600 kW for hydraulic oil
Fluid specifications	Diesel fuel, Mazut and oil
Pump service pressure	30 to 80 bar depending on the type of fluid
Pump flow rate	400, 800 and 1000 litres per minute

Advantages:

- ※ Providing high pressure and high flow
- ※ Low depreciation and maintenance cost

International Standards or Permissions:

- ※ API 676
- ※ API 672



➤ Testing Dynamic Parameters of Power Plant Units

◆ Hesam intelligent monitoring systems (HIMS) Co.

www.hims.co.ir



Product Introduction:

The first step towards the safe use of the network is to conduct accurate and timely studies on the network; However, conducting any detailed study on the network requires an accurate static and dynamic model of the network, whose accuracy has been evaluated periodically. Having a suitable model for the network and conducting various studies can lead to reducing the number of unwanted exits, increasing the life of equipment, optimal utilization of the existing capacities of power plants and improving the quality of electrical grid. Currently, the available models of these production units are not accurate enough and do not represent the actual performance of power plants in any way. Accordingly, all power plant units should conduct identification tests. These tests for each power plant unit are divided into three categories: synchronous generator parameters estimation and evaluation tests, identification of the model and parameters of the stimulation and the power system stabilizer, identification of the model and parameters of the turbine-governor system. These tests require information acquisition equipment with a very high sampling rate and complete technical knowledge of how the power plant works. Also, it includes things such as changing the reference signals of the control devices, opening the network breaker in different active and reactive loads, and injecting the required signals to the control devices of the power plant.

Founded:

2015

Application:

- * Validation and identification of synchronous generator
- * Validation and identification of the stimulation and voltage regulator (AVR) system
- Validation and identification of turbine governor and boiler system (steam units)
- * Validation and identification of the boiler system and HRSG (combined cycle units)

This product is final B2B service.

Technical Specifications:

- * Using isolated data acquisition devices (Data Logger) with high sampling rate (1 KHz)
- * Measuring the load angle of the synchronous generator using a load angle measuring device (Load Angle Meter)
- * Conducting tests of combined cycle units in an integrated and simultaneous manner (two gas units and a steam cycle unit) and estimating boiler and HRSG system parameters.

International Standards or Permissions:

- * IEEE 115-2009
- * IEC60034-4-2018



➤ Aluminizing by Cementation Pack Method for Turbine Blades

◆ Khamsa Industry Science Co.

STEX

Product Introduction:

In the aluminizing method, which is one of the thermochemical processes, a rich layer of aluminum is formed on the surface of the parts. There are different methods for aluminizing, the most important of which is the Pack cementation method. In this method, the parts are placed in a powder mixture containing aluminum, chromium and alumina powder. Using an activator, this mixture leads to the formation of vapors of aluminum halides, and after the deposition of these vapors on the surface of the workpiece, a rich layer of aluminum will be formed. As a result of applying heat and then atomic penetration, aluminum penetrates the surface of the parts and forms an diffusion layer. Cementation pack is currently the most economical method of applying aluminizing coatings.

This product is final B2B service.

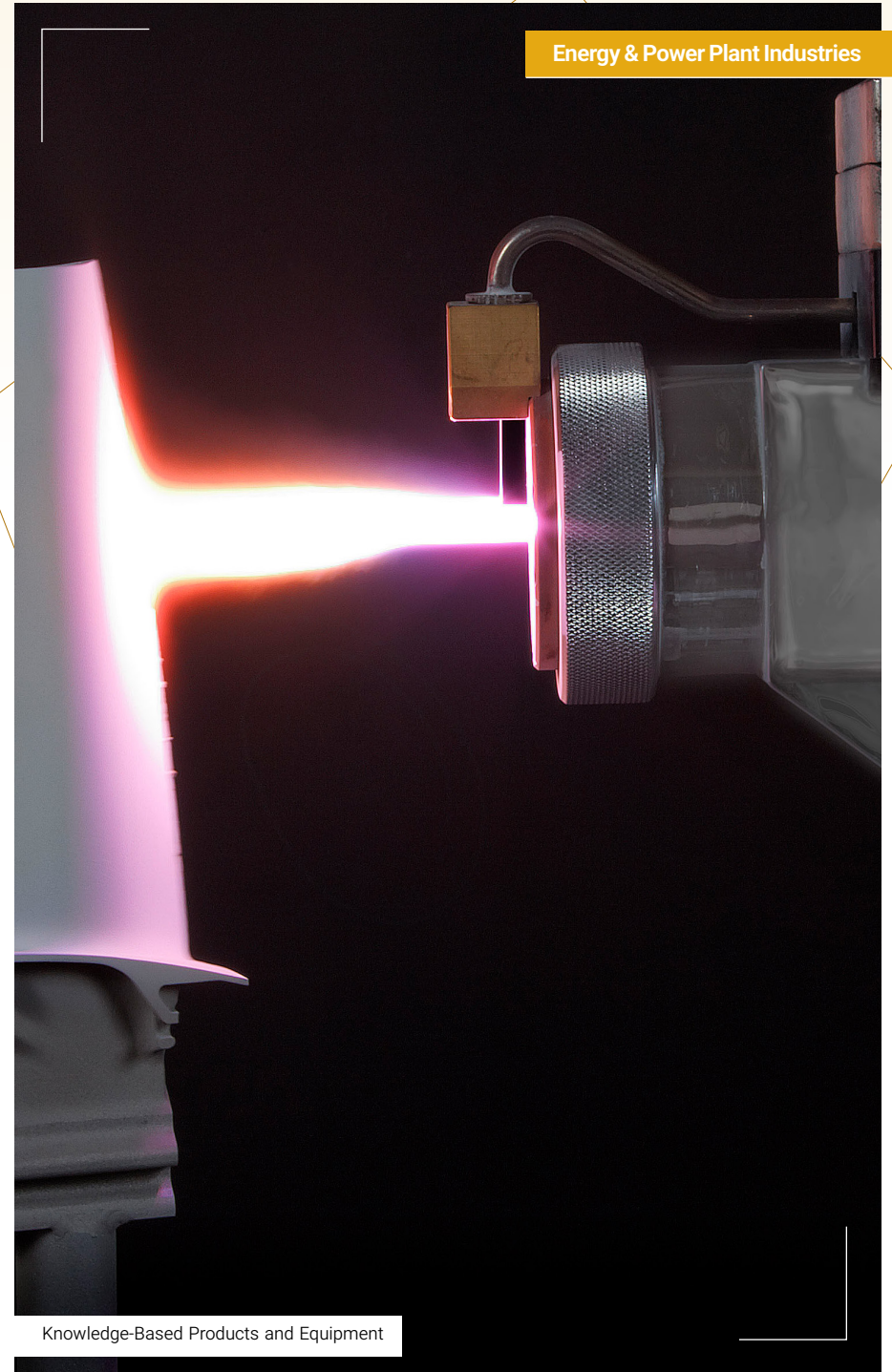

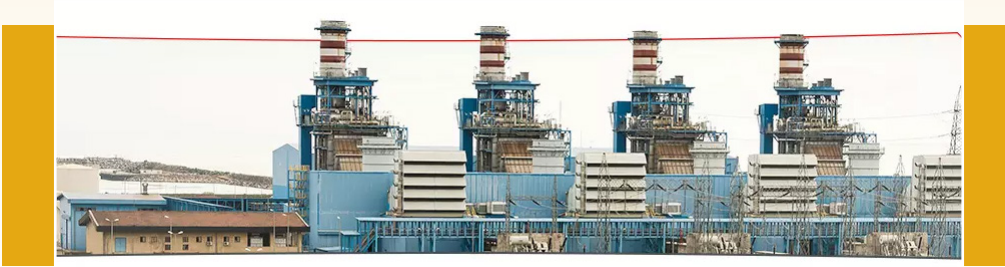

➤ Power Plant Heat Recovery Boilers (HRSG) Class E (Flow Rate TON_HR 270) and F (Flow Rate TON_HR 340) Horizontal Type

◆ Mapna Boiler & Equipment Engineering & Manufacturing Co.
www.mapnabe.com



Product Introduction:

The product of the heat recovery boiler (Heat Recovery Steam Generator) is placed downstream of the gas turbine in combined cycle power plants. Therefore, the very significant amount of energy of the exhaust gas flow from the high-temperature gas turbine (around 550-570 degrees Celsius and above) instead of being wasted and released and into the atmosphere in simple gas cycle power plants, is sent to the heat recovery boiler by the exhaust smoke duct, and in the heat recovery boiler by transferring the energy of the smoke to the water/steam fluid inside the pipes of this type of boiler, the temperature of the smoke decreases significantly (about 85-105 degrees Celsius) and it goes out to the atmosphere from the chimney of the boiler. Therefore, the energy transferred to the water cycle and boiler causes the production of steam and superheating, and this produced steam causes the production of power in the steam turbine generator by moving between the blades of the steam turbine; Therefore, the efficiency of the simple cycle of the gas turbine which is about 35-40%, increases to the efficiency of the combined cycle of about 55-61% by using the heat recovery boiler and steam turbine and other necessary equipment such as the condenser (as a steam unit versus the gas unit). Also, this efficiency increase of about 20% for the same fuel consumption in two simple gas turbine cycles and combined gas-steam cycle means a significant increase in power production.

Export History:

Between 1,000,000 - 10,000,000 \$

Founded:

2008

Application:

Combined cycle power plants

This product is final B2B equipment.

Technical Specifications:

Heat recovery boilers consist of four main parts:

- ※ Super heater
- ※ Operator
- ※ Economizer
- ※ Water preheater



➤ Power Plant Heat Recovery Boilers (HRSG) Class E (Up to 240 TON_HR Capacity) of Horizontal Type

◆ AzarAb Industries Co.

www.azarab.ir



Product Introduction:

The heat recovery boiler (HEAT RECOVERY STEAM GENERATOR) is placed on downstream of the gas turbine in combined cycle power plants. In this way, the very significant energy of the exhaust gas flow from the high-temperature gas turbine (about 550-570 degrees Celsius and higher), instead of being wasted and released into the atmosphere in simple gas cycle power plants, is emitted by the exhaust smoke duct to the heat recovery boiler, where by transferring the energy of the smoke to the water/steam fluid inside the pipes of this type of boiler, the temperature of the smoke decreases to a significant extent (about -105 85 degrees Celsius) and exits the boiler chimney towards the atmosphere; Therefore, the energy transferred to the water cycle and boiler causes the production of steam and its superheat, and this produced steam by moving between the blades of the steam turbine causes the production of power in the steam turbine generator; Therefore, the efficiency of the simple cycle of the gas turbine which is about 35-40%, increases to the efficiency of the combined cycle of about 55-61% by using the heat recovery boiler and steam turbine and other necessary equipment such as the condenser (as a steam unit against the gas unit). Also, this efficiency increase of about 20% for the same fuel consumption in two simple gas turbine cycles and combined gas-steam cycle means a significant increase in power production.

Main Export Destinations:

Turkey, Syria

Export History:

Between 1,000,000 - 10,000,000 \$

Founded:

1985

Application:

Used in all kinds of turbines

This product is final B2B equipment.

Technical Specifications:

- ※ Simpler design compared to output power
- ※ Shorter time to generate steam
- ※ Optimal use of thermal energy
- ※ Reducing environmental pollution due to lowering the temperature of exhaust gases and its optimal reuse



► Industrial Boilers (SD Type), Package (SC type) and Power Plant Boilers (SR and SN) | with Natural Circulation System

◆ AzarAb Industries Co.

www.azarab.ir



Product Introduction:

Boilers are equipment used in industries to produce hot water steam with high temperature and pressure. Boilers used in power plants are known as power plant boilers. These boilers are used to generate extremely high pressure in order to generate electricity. The process that is carried out in these boilers as a cycle is known as the RANKINE cycle.

- ※ **SR type boiler:** This type of boiler is used to produce steam in thermal power plants. This boiler is designed and built with a natural water circulation system, as a single drum, and has several stages of Super Heater, Reheater, and Economizer.
- ※ **SN type boiler:** This type of boiler is a single drum and the natural water circulation system is supported by a top supported structure. This boiler does not have a steam reheater and is suitable for low power generation capacities.
- ※ **SD type boiler:** This type of boiler is made as an industrial boiler in different sizes and is made in separate sets and then assembled together at the site. This boiler is installed on a concrete foundation (Bottom Support).
- ※ **SC type boiler:** This type of boiler can be built and assembled in the workshop, and in case of transportation restrictions, it can also be made in the form of prefabricated parts that can be assembled on site. This boiler is produced to produce saturated steam or super heat steam.

Main Export Destinations:

Turkey, Syria

Export History:

Between 1,000,000 - 10,000,000 \$

Founded:

1985

Application:

Generating extremely high pressure in order to generate electricity

This product is final B2B equipment.

Technical Specifications:

SR type boiler	
Fuel	Gas, Diesel and Mazut
Maximum steam temperature	550 degrees Celsius
Maximum pressure	180 kg/cm ² g
Capacity	From 390 t/h to about 2000 t/h
SN type boiler	
Fuel	Gas, Diesel and Mazut
Maximum steam temperature	545 degrees Celsius
Maximum pressure	150 kg/cm ² g
Capacity	From 80 t/h to about 600 t/h
SD type boiler	
Fuel	Gas, Diesel and Mazut
Maximum steam temperature	505 degrees Celsius
Maximum pressure	127 kg/cm ² g
Capacity	From 40 t/h to about 350 t/h
SC type boiler	
Fuel	Gas and Diesel
Maximum steam temperature	450 degrees Celsius
Maximum pressure	120 kg/cm ² g
Capacity	From 00 t/h to about 200 t/h

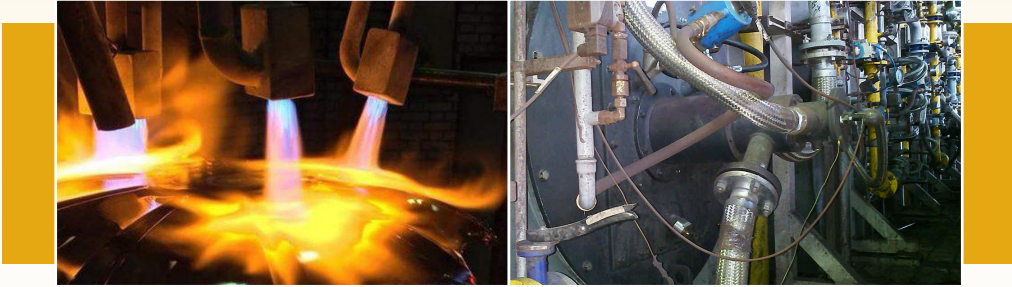

➤ Combustion System with Burners of WBGO Power Plant Boilers

◆ Sholeh Sanat Manufacturing & Engineering Co.

www.sholehsanat.com

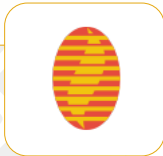

Product Introduction:

The name of this type of burners is derived from the initial letters of the phrase Water Tube Boiler Gas/Oil. In traditional burners of this type, there is a great amount of the NO_x pollutant and its amount is not below 380ppm in any of these burners. The main body of the burner is made of ordinary sheet, but the precision in shaping plays a great role in the performance of the burner. The existence of air directing valves in this burner is very important and creates the ability to shape the flame. The heat diffuser, which plays an important role in the stability of the flame, is made of superalloys, and the fuel injection nozzles (gas, diesel or Mazut) are usually made of anti-wear steel.

Founded:

1988

Application:

Water-tube type steam boilers

This product is final B2B equipment.

Technical Specifications:

Thermal capacity	4,000,000 - 60,000,000 kcal/h
Adjustment range	※ 6 to 1 in gas mode ※ 4 to 1 in liquid fuel mode
Service temperature	Up to 1100 degrees Celsius

Advantages:

Lower price than similar products

International Standards or Permissions:

- ※ BS EN 676 & 267 & 298 & 13611
- ※ ISO 5167
- ※ API 535 & 560
- ※ EN 746
- ※ IGS 104 & 106
- ※ BS EN 50379



➤ Designing the Cooling System of the Main and Auxiliary Air Condenser of a Power Plant (Air Cooled Condenser)

◆ Mapna Group MD1 Co.

www.mapnamd1.com



Product Introduction:

One of the main components of combined cycle power plants is the cooling system of the power plant, which is designed and executed with different mechanisms according to the needs of the system and design conditions. Due to the limitation we face in the use of water resources, air cooling systems or ACC (Air Cooled Condenser) are among the cooling systems that are receiving a lot of attention today. Since the expanded steam in the turbine is no longer able to perform work and generate power, its remaining heat must be wasted in order to be transformed to liquid again, which can be returned to the cycle using a pump. The latent heat of vaporization is taken from the fluid through the flow of cooling air passing over the air-cooled exchangers. After completing the heat transfer process, the produced condensate is delivered to the boiler by CEP pumps to regenerate steam.

Founded:
2004

Application:

- ✦ Power plants with a variety of cooling systems, including Heller, ACC and Wet (for all cooling systems except single-pass cooling systems)
- ✦ Other sites and plants, if side cooling systems are needed

This product is final B2B equipment.

Advantages:

Rotating equipment	<ul style="list-style-type: none"> ✦ CEP pumps ✦ Hotwell Drain pumps ✦ Fans ✦ Gearbox
Modules	12 tube bundles (each tube bundle includes 38 tubes of 11.2 meters with a fan with a diameter of 34 feet)

Advantages:

- ✦ Solving the problem of freezing in cold times of the year
- ✦ Significant reduction in water consumption
- ✦ Reducing maintenance and repair costs by increasing the equipment life cycle



➤ EXHAUST System of Power Plants with Different Capacities

◆ Sepahan Mapna Engineering & Equipment Manufacturing Co.

www.mapnasts.ir



Product Introduction:

The main task of this equipment is to transfer the exhaust gases of the turbine to a height higher than the turbocompressor and release it into the atmosphere. The exhaust gases of the turbine have a high temperature, and along this path, their temperature decreases and finally they enter the atmosphere with a low temperature. The intensity of the flow of current in this path causes abnormal sound. For this reason, in the middle of the path, it passes through a set of sound absorbers and the intensity of the sound frequency is reduced. The set of sound absorbers is called a silencer.

Founded:

1996

Application:

Transferring the exhaust gases of the turbine to a height higher than the turbocompressor and releasing it into the atmosphere

This product is final B2B equipment.

Advantages:

Material	Steel and stainless steel
The temperature of the gases entering the exhaust	At least 400 degrees Celsius
The temperature of the gases exiting the exhaust	150 degrees Celsius



➤ AIR INTAKE System of Power Generation Plants with Different Capacities

◆ Sepahan Mapna Engineering & Equipment Manufacturing Co.

www.mapnasts.ir



Product Introduction:

This equipment has the task of providing the air required for the combustion chamber of the turbine. The intake air system of gas turbines provides the cleaned air with the required speed, temperature, pressure and sound level in the standard level for the compressor part of the turbine. By passing through this system, the ambient air is directed to the compressor after filtration to be ready for consumption in the combustion chamber of the turbine after compression and reaching a certain temperature. Considering the importance of this part in the performance and efficiency of the turbine, the design and construction of this complex is highly sensitive. This system is a collection of channels and peripheral equipment related to it which is designed for specific purposes and tasks.

Founded:

1996

Application:

- ✳ Filtering the incoming air from dust and polluting particles, taking into account the required flow rate of the turbine
- ✳ Damping (removing) the sound produced by the turbine
- ✳ Guiding the air towards the turbine with the right angle
- ✳ Adjusting the input air temperature to prevent freezing of the filters and the air path to the turbine

This product is final B2B equipment.

Advantages:

Opening dimensions	3 × 4 – 12 × 12 m
Air filtration efficiency	95%
The material of sheets used	S235JR



➤ Designing the Air Cooling System of Power Plant ACC (Air Cooled Condenser)

◆ Monenco Iran Consulting Engineers Co.

www.monencogroup.com



Product Introduction:

ACC (Air Cooled Condenser) air cooling system is one of the types of power plant dry cooling systems. The steam coming out of the steam turbine enters the ACC system in an almost saturated state, and after transferring heat to the distilled ambient air, it leaves the system in a saturated liquid state and is returned to the power generation cycle. The importance of the cooling system is that it provides the pressure behind the steam turbine and its performance affects the performance of the power plant (production power and efficiency). The converters of the new ACC systems are of single-row type with aluminum blades. The main components of the ACC system are the steam distribution and transmission duct system, heat exchangers, fan system, distilled fluid collection system, excess gas removal system and heat exchanger surface cleaning system. This cooling system is also used in other industries.

Founded:

1973

Application:

- * Power plant industries
- * Oil and gas and petrochemical industries

This product is final B2B equipment.

Advantages:

Number of ACC modules for combined cycle power plants	6 × 4 or 7 × 4
Module	Consists of 12 bundles
Bundle tube material	Carbon steel
The length of the tubes	9.5-10.5 m

Advantages:

- * Low water consumption (almost negligible) among cooling systems
- * Ability to design the system in a modular way
- * %50 weight reduction of heat exchangers by using single row exchangers
- * %20 reduction in fan power consumption by reducing the pressure drop on the air side by using single converters
- * Use of VFD system to manage electrical energy consumption
- * The possibility of designing the structure in metal or concrete form



➤ **Design, Equipment Supply, Installation, Repair and Maintenance Services Related to Hydroelectric Power Plants on Water Transmission Lines Up to 10 Megawatts**

◆ **Roshd Sanat Co.**

www.roshdsanatniroo.com



Product Introduction:

In order to convert the potential energy of the fluid (water) in the transmission lines into electrical energy on the water transmission lines, turbine or PAT pumps (the pump is used as a turbine, although its efficiency will be lower than the turbine, but considering the difference in the cost of electricity production, it is justified) are installed and their output goes to the coupler generator; In this way, on-line hydropower plants are built. Due to the fact that the water pressure in the transmission lines is high and near the cities, it is necessary to lower the pressure for consumption with pressure relief valves, therefore, by using a chain of one or more hydroelectric power plants, of the turbine type or PAT type, or a combination of turbine and PAT, instead of wasting energy, it can be converted into electricity.

Founded:

1990

Application:

Hydroelectric power plant

This product is final B2B service.

Advantages:

Hydroelectric power plant on the water transmission line	3 MW, 6.4 MW and 8.3 MW
Chain stations	Up to 6 stations (5 turbine type and one PAT type)
Electric motors	315 and 160 kW SIEMENS
Input fluid flow rate	Each unit is 19 cubic meters per second

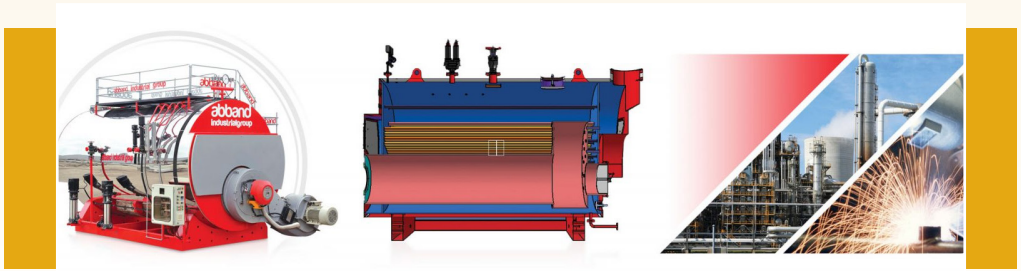

Application:

- * Passing through nozzles and directing steam
- * Increasing thermal efficiency in steam turbines

➤ **Power Plant Auxiliary Boilers**

with a Capacity of More than 15 Ton/Hr Super Heat Steam

◆ **Ab band Industrial Group**

www.ab-band.com



Product Introduction:

Boilers made by Abband Industrial Group are designed with BS 2790-1992 standard and have been approved by several reputable European companies; These types of boilers are produced and marketed in the capacity of 60 kg/hr to 3000 kg/hr with different working pressure. The types of these boilers are: steel firetube, horizontal, triple-pass, wetback. All these items are designed with high quality and high efficiency and the ability to work with gas, Mazut and diesel fuels. All welding lines are carefully inspected by performing radiographic, ultrasonic and dye penetrant tests under the supervision of quality control experts.

Founded:

1996

This product is final B2B equipment.

Advantages:

Capacity	From 16000 to 30000 kg/h
Service pressure	Up to 450 pounds per square inch or according to customer's request
Hydrostatic test pressure	1.5 times the design pressure
Vapor temperature	At a pressure of 150 pounds per square inch of saturated steam with a temperature of 185 degrees Celsius

Advantages:

- * Ease of maintenance and repair
- * Being small
- * High strength and efficiency

International Standards or Permissions:

- * BS 2790-1992
- * BS 1501-151 GR 430A
- * BS 3059 Part 1 H.F.S
- * BS 3602 GR.23 OR 27 H.F.S



➤ Redesigning and Manufacturing Parts of Bypass and Spray Water Valves of Power Plants

◆ Turbine Compressor Asia Co.

www.tuca-co.com



Product Introduction:

Bypass literally means passage or detour. But in plumbing, bypass is a system consisting of pipes and bypass valves, which establishes fluid flow around a particular plumbing system in a separate path. The bypass route in piping is also known as the temporary route. In this system, water or sewage is allowed to flow through the bypass route to the outlet or consumer when the main fluid piping path is closed or unusable due to reasons such as repair. The use of the bypass system in piping assures that when there is any problem with the piping system or the main path of the fluid flow, the movement of the fluid will not be stopped.

Founded:

2011

Application:

In any system that uses liquid or even gas flow.

This product is final B2B equipment.

Advantages:

Bypass

- ※ **Input:** Steam that comes out of the boiler
- ※ **Steam temperature:** 550 degrees Celsius
- ※ **Steam pressure:** 220 bar



➤ Water and Energy Resources Management System (Dam and Power Plant)

◆ Radman System Pooya Gostar Co.

www.rspgco.ir



Product Introduction:

The water and energy resource management system produced by this company is related to the power plant operation system. Finally, it predicts the production and evaluates the performance of the power plant based on international standards.

Founded:

2014

Application:

- * Dam and power plants
- * Tavanir
- * Water and` electricity organizations

This product is final B2B service.

Advantages:

- * Asp.net
- * Sql server
- * Entity framework
- * JQuery

Advantages:

Using international software and standards and power plant and production evaluation indices using smart algorithms

Second Chapter
Water and Sewage Treatment



2nd CHAPTER

First Chapter

Second Chapter

Third Chapter

Fourth Chapter

Fifth Chapter

Water and Sewage Treatment

Thermal Desalination (MED-TVC) | 236

MED-TVC Water Desalinators | 238

Thermal Desalination System (MED-TVC) | 240

Distillation Screen Water Desalination | 242

Wastewater Treatment Using Advanced Oxidation Methods, Electrochemical Oxidation and Electrocoagulation on an Industrial Scale | 244

Industrial Wastewater Treatment Package | 246

Providing Deep Water Identification Services | 248

Sections

- Water Desalination ○
- Wastewater Treatment ○
- Deep Waters ○



➤ Thermal Desalination (MED-TVC)

◆ Farazarab Engineers Co.

www.farazarab.com



Product Introduction:

In general, the existing methods of preparing fresh water can be divided into two categories: thermal and membrane methods. Each of the mentioned methods has its own advantages and disadvantages, and therefore, choosing the best water desalination method depends on the location, geographic conditions of the region, available energy, and other such factors. The MED-TVC multi-stage evaporator system is a system based on heat energy, which is classified as a thermal process in the classification of water desalinators. This system is the first and most important method of producing pure water from the sea, which works under vacuum, and the basis of its work is the condensation of vapors from sea water. In this system, which uses a thermocompressor to create a vacuum, two flow lines enter the system, one of which is related to the used steam and the other is the incoming impure water. This steam can be supplied in different ways, one of the most economical of which is the use of the waste heat from power plants.

Founded:

2014

Application:

Production of fresh water with high purity for industrial or drinking purposes

This product is final B2B equipment.

Technical Specifications:

- * **Capacity:** 50 to 30,000 cubic meters per day
- * **Maximum unit temperature:** 65 degrees Celsius
- * **Vacuum:** Above %95
- * **Incoming water solutes and minerals:** More than 45,000 ppm

Advantages:

- * Technology and design of BASKET FILTER filters with a very long life
- * Technology and design of steam ejectors in one stage to provide full vacuum (more than %93)
- * Thermocompressor technology and design with different SOURCES of steam pressure and with variable flow rates

**Application:**

Power plant industries

➤ MED-TVC Water Desalinator

◆ Fan Niroo Co.

www.fanniroogroup.com

**Product Introduction:**

Considering the problems caused by the lack of water in different parts of the world, paying attention to alternative water sources and studying various methods in order to use water with suitable qualities for various purposes is increasing significantly. Oceans and seas are huge sources of water in the world, which are practically impossible to use directly due to the high weight percentage of impurities. For this reason, various methods and equipment have been used all over the world to prepare fresh water from these sources. In general, the available methods of preparing fresh water can be divided into two categories: thermal and membrane methods. The MED-TVC multi-stage evaporator system is a system based on heat energy, which is placed in the category of thermal processes in the classification of water desalinators. This system is the first and most important method of producing pure water from the sea, which works under vacuum, and the basis of its work is the condensation of vapors from sea water. In this system, which uses a thermocompressor to create a vacuum, two flow lines enter the system, one of which is related to the used steam and the other is the incoming impure water. This steam can be produced in different ways, one of the most economical of which is the use of the waste heat from power plants.

Founded:

1992

This product is final B2B equipment.

Technical Specifications:

- * **Capacity:** 7800 m³ a day
- * **Steam required by MED unit:**
 - * Temperature of 385 degrees Celsius
 - * Pressure of 37 bar gauge
- * **Vacuum pressure:** 888 mbar

Advantages:

- * The possibility of using the thermal waste energy of power plants
- * Evaporation at low temperatures (less than 70 degrees Celsius, due to working pressure conditions)
- * High purity of produced water without influence from incoming water



➤ Thermal Desalination System (MED-TVC)

◆ Bonian Daneshpajouhan (BDP) Co.

www.bonian.org



Product Introduction:

Oceans and seas are huge sources of water in the world, which are practically impossible to use directly due to the high weight percentage of impurities. For this reason, various methods and equipment have been used all over the world to prepare fresh water from these sources. In general, the existing methods of preparing fresh water can be divided into two categories: thermal and membrane methods. The best desalination method is selected according to the amount and type of impurities, location, geographical conditions of the region, available energy and other factors. The MED-TVC multi-stage evaporator system is the first and most important method of producing pure water from the sea, which works under vacuum, and the basis of its work is the condensation of vapors from sea water.

Founded:

2002

Application:

Converting salt water to pure water

This product is final B2B equipment.

Technical Specifications:

- * **Steam incoming into the units:** 3 bar and higher
- * **Operating temperature of the unit:** Lower than 70 degrees Celsius

Advantages:

- * Making it possible to use low pressure steams in the design and operation of thermal units
- * Reducing steam consumption by optimizing thermocompressor and ejector nozzles
- * Reducing electricity consumption by optimizing the design and increasing NPSH of pumps
- * Extending the lifespan and improving the operating conditions



Application:

- * Converting salt water to fresh water in all areas that suffer from drought or salt and nitrate water
- * Remote areas that have polluted and limited water resources

➤ Distillation Screen Water Desalination

◆ Yasin Pajoo Parsian Ebtakar Co.

www.yasinpajoo.com



Product Introduction:

With the help of the distillation screen water desalination device, you can desalinate salt water while saving energy. The membrane distillation process is based on gas-liquid equilibrium and permeation through a hydrophobic membrane. In this process, first the liquid evaporates on the side of the hot feed, then the steam passes through the membrane, and on the other side of the membrane, this penetrating steam is condensed. The incoming feed is placed in contact with the membrane at a temperature of 40 to 80 degrees Celsius, and due to the difference in steam pressure on both sides of the membrane, which is a result of the temperature difference, the steam penetrates through the hydrophobic membrane.

Founded:

2013

This product is final B2B equipment.

Advantages:

Production of distilled water at very low pressure and temperature lower than the boiling point of water along with the use of solar energy



➤ **Wastewater Treatment Using Advanced Oxidation Methods, Electrochemical Oxidation and Electrocoagulation on an Industrial Scale**

◆ **Payamavaran NanoFanavary Fardanegar (PNF) Co.**

www.pnf-co.com



Product Introduction:

Payam Avaran Fardanegar Nano Technology Company has developed new technologies in the field of industrial wastewater treatment based on advanced oxidation process (AOP). This technology is called Cavizone, which consists of the process of producing Nano ozone (Nano Ozone Generator), electrocoagulation (EC), electrochemical oxidation (EO) and the use of nano iron (NZVI). In the nano method, air bubbles or ozone gas on a nanometer scale are produced in water, which acts as a micro-coagulant with greater stability and durability and causes coagulation of pollutants. In the E and EC methods, the function is similar in the coagulation of pollutants, but this time it is done by electric current and causes the separation of pollutant ions or macromolecules such as the color in the wastewater and COD. With a special design and the use of appropriate combined methods, the treatment of wastewater from various industries including textile, petrochemical, polymer, food, etc., has been achieved with impressive results.

Founded:

2007

Application:

Reduction of BOD and COD from all kinds of agricultural and industrial effluents

This product is final B2B equipment.

Technical Specifications:

Filtration capacity	25 litres per hour
Required power	550 W
Water purification efficiency	Higher than 95 %
Power distribution specifications	220 V AC
Operating temperature range	50-5 degrees Celsius

Advantages:

- * Low energy consumption
- * Minimal consumption of chemicals
- * Reasonable operating cost
- * Small occupied space

International Standards or Permissions:

Quality control test including COD and color



➤ Industrial Wastewater Treatment Package

◆ Nilfam Engineering Co.

www.nilfam-co.com



Product Introduction:

Consequences of reducing the quality and pollution of water resources cause an increase in treatment costs and the spread of various diseases. Reusing treated wastewater with the aim of preventing environmental destruction and using it sensibly is the only way to deal with water scarcity and is considered one of the main goals of this team. Wastewater treatment is done with the help of physical processes (such as screening, grain collection, degreasing, sedimentation, filtration), or biological (such as anaerobic and aerobic bioreactors) and chemical (such as chlorination, ozonation) processes separately or in combined.

In most cases, the amount of wastewater produced by residential, office buildings, industrial or educational units is so much that it is not cost-effective to build a treatment plant with separate units, because in addition to occupying a lot of land, the cost of the treatment system also increases sharply. Biological wastewater treatment packages with integrated growth method have more advantages than conventional activated sludge processes.

Founded:

2010

Application:

Sewage treatment of communities, rural and sparsely populated areas that have or do not have a collection network.

This product is final B2B equipment.

Technical Specifications:

Wastewater treatment by physical method:

- * Screening
- * Degreasing by gravity method
- * AP
- * Filtration

Wastewater treatment by biological method:

- * IFAS methods
- * MBBR methods

Wastewater treatment by chemical method:

- * Injection of chemicals
- * AOP
- * Disinfection by chlorination and UV

Advantages:

- * The best quality of the outgoing effluent and beyond the standards of the Environmental Protection Organization
- * Ability to use wastewater for agriculture, green space irrigation and recirculation in industries
- * Completely odorless

International Standards or Permissions:

- * EN ISO 9001 : 2015 UNE
- * BS OHSAS 18001:2007
- * UNE-EN ISO 14001:2015
- * ISIRI-ISO 14001:2015



➤ Providing Deep Water Identification Services Using Devices Based on Magnetotelluric Technology (MT_AMT)

◆ ZAP (ZAMIN AB PEY) Consulting Engineers Co.

www.zapce.net



Product Introduction:

The current product is to provide deep water identification services and provide a suitable location report for test drilling and exploiting and use of these waters. The identification process is carried out using devices based on magnetotelluric technology (AMT/MT). In the magnetotelluric detection method, natural electromagnetic waves of the earth are used to check the electrical conductivity of subsurface materials. For this purpose, the changes of magnetic and electric fields are measured simultaneously and a mixed ratio called impedance and phase is calculated. These natural oscillations are caused by the ionosphere, which in the low frequency domain is related to solar activity and in high frequencies is related to lightning activity. The present service is performed by combining geological, sedimentology, geochemistry, geophysics data in the GIS environment and choosing appropriate definitions as well as collecting historical data related to the existence of fresh water.

Founded:

2001

Application:

Providing deep water identification services and providing appropriate location reports for test drilling and exploiting and use of these waters.

This product is final B2B service.

Technical Specifications:

Stages and phases:

1. Identify potential areas by reviewing available baseline data and collecting new data
2. Using geophysical and geological methods to identify and determine water zones in the possible areas
3. Test drilling
4. Investigations of tracing, isotope, water quality, hydrogeology, amount of storage and drainage
5. Management planning by the company's expert forces regarding the drilling of the exploitation well and its development

Advantages:

- * Use of MT/AMT technologies
- * Georadar and special resistance method and induction polarization in identifying new resources

Third Chapter

Solar Cells



3rd CHAPTER

First Chapter

Second Chapter

Third Chapter

Fourth Chapter

Fifth Chapter

Solar Cells

- Photovoltaic Solar Panel Produced | 254
- Transparent Titanium Dioxide Electrode | 256
- Crystalline TiO₂ Sol in Ethanol | 258
- Acidic Aqueous TiO₂ Sol | 260
- Nanostructured Solar Cells Making and Characterization Set | 262
- Anti-Reflective Solar Cell Coating with High Efficiency | 264
- Luminescent Solar Concentrator Module Using Bifacial Photovoltaic Cells | 266
- A Research Inverter Connected to the Grid | 268
- High Performance Electrolyte | 270
- Standard Electrolyte | 272

Sections

- Cells and Coatings ○
- Inverters ○
- Electrolytes ○



➤ Photovoltaic Solar Panel Produced Using Silicon Solar Cells

◆ Mana Energy Pak Co.

www.mepcell.com



Product Introduction:

Solar energy is obtained from sunlight. The solar panel (or photovoltaic effect) converts sunlight photons (energy particles) into electricity. Solar panels absorb photons and generate electric current. The energy produced from photons will allow electrons to leave their atomic orbits and be released in the electric field produced by solar cells; This electric field directs the free electrons in the electric current. The mentioned process is called photovoltaic effect. The roof of a house has enough space to install the solar panels needed to produce electricity. Also, solar panels generate additional electrical energy during the day, so that this energy can be used at night.

Founded:

2017

Application:

- * Power control of the system of chambers and communication equipment
- * Sensor control and electricity generation by home and commercial solar electric systems

This product is final B2B equipment.

Technical Specifications:

Dimensions	157mm × 157mm±0.25mm-Φ210mm±0.25mm
Thickness	180±20µm

Advantages:

- * Not using electricity
- * No need for cabling and mast
- * Clean and environmentally friendly energy



Application:

Solar cell research laboratories

➤ **Transparent Titanium Dioxide Electrode**

◆ Sharif Solar Co.

www.sharifsolar.ir



Product Introduction:

The meso-TiO₂ transparent electrode consists of a mesoporous TiO₂ layer with a thickness of several microns on FTO. This layer is completely transparent due to the particles being single size and uniform. This electrode is used to make pigmented solar cells. Before use, it is better to place the electrode at a temperature of 500 degrees Celsius for a few minutes so that its surface is completely cleaned and prepared for pigment absorption.

Founded:
2014

This product is a final B2B consumer product.

Technical Specifications:

Layer	Glass/FTO
Coating	Meso-TiO ₂
Deposition method	Printing
Thickness	6-7 μm
Colour	Transparent

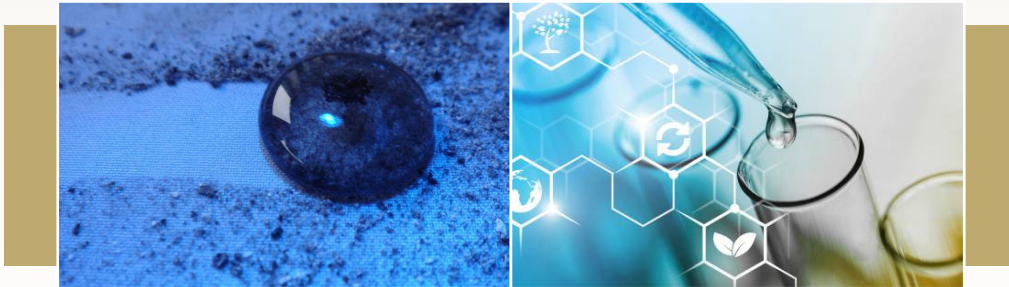

► Crystalline TiO₂ Sol in Ethanol

◆ Sharif Solar Co.

www.sharifsolar.ir



Product Introduction:

This colloidal solution contains titanium dioxide nanoparticles with a size of 20 nm dispersed in ethanol (with a small percentage of water). It is usually used whenever there is a need for an ethanolic solution, such as some layering methods.

Founded:

2014

Application:

- * Solar cell research laboratories
- * Used on self-cleaning surfaces

This product is a final B2B consumer product.

Technical Specifications:

Particle size	About 20 nm
Concentration	0.1 wt%
Physical state	Liquid dispersion
Colour	White
Solvent	Ethanol

Advantages:

- * Lower price than similar products
- * Proper zeta potential and prevention of deposition and agglomeration of nanoparticles

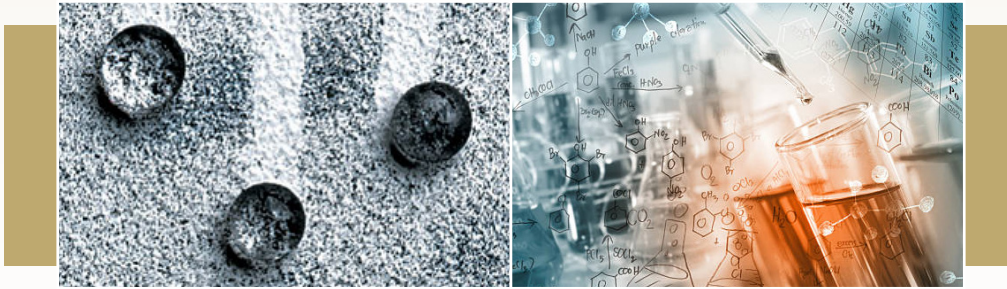

➤ Acidic Aqueous TiO₂ Sol

◆ Sharif Solar Co.

www.sharifsolar.ir



Product Introduction:

This colloidal solution contains titanium dioxide nanoparticles with a size of 6 to 10 nanometers, in an amorphous phase and in an acidic environment. The solution is 5% by weight and it can be used for TiO₂ coating or as a precursor for making crystalline nanoparticles.

Founded:

2014

Application:

- ※ Solar cell research laboratories
- ※ Used on self-cleaning surfaces

This product is a final B2B consumer product.

Technical Specifications:

Particle size	Less than 10 nm
Concentration	1 wt%
Physical state	Liquid dispersion
Colour	Transparent
Solvent	Water

Advantages:

- ※ Lower price than similar products
- ※ Proper zeta potential and prevention of deposition and agglomeration of nanoparticles

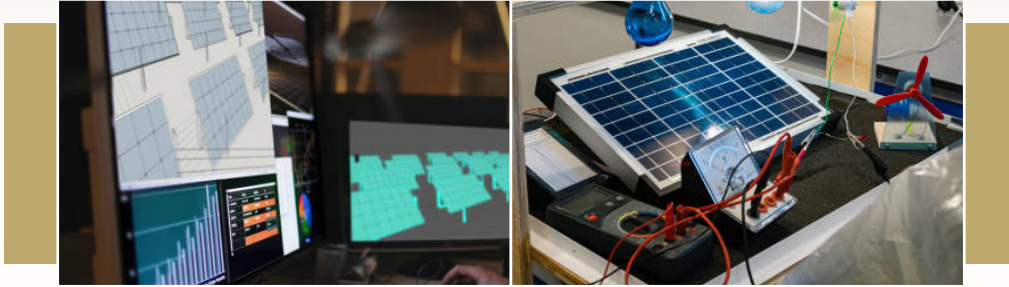

➤ Nanostructured Solar Cells Making and Characterization Set

◆ Pajoo Afzar Lian Co.

www.lianware.ir

Product Introduction:

This collection has been designed and produced to be used in educational and research centers in the field of manufacturing third generation solar cells and for using nano technology to increase the efficiency of these cells. Thus, four complementary sets have been designed and built, which are: 1-Quantum yield measurement set 2-Solar simulator set 3-Solar cell table laboratory set 4-Spectroscopy set . With the help of the quantum yield measurement set, it is possible to study the yield of the cell in various spectral regions by splitting the white light from the xenon lamp into desired wavelengths and shining it on the solar cell under investigation. A solar simulator is used to generate a continuous spectrum that can resemble the spectrum of the Sun or any desired spectrum. The laboratory table consists of various parts including a common solar package (solar panel, charge controller and inverter), solar power meter, light source with adjustable intensity and cell current-voltage measurement equipment. In the spectroscopy system, in order to investigate the optical properties of plasmonic nanoparticles and the formation of surface plasmon in them, LED power is used as a light source.

Founded:

2010

Application:

- ※ Taking a spectrum of materials
- ※ Characterization of nanostructures
- ※ Examining the spectrum of light sources and the spectrum produced by the solar simulator

This product is final B2B equipment.

Advantages:

The advantages of using LED power instead of gas lamps are:

- ※ Stable radiation
- ※ High efficiency
- ※ Low price
- ※ Long life
- ※ No need for a cooling system
- ※ Small dimensions
- ※ Easy setup

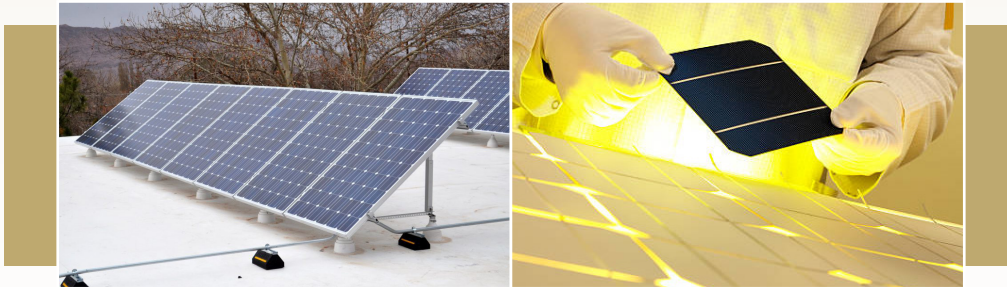

➤ Anti-Reflective Solar Cell Coating with High Efficiency

◆ Avije Akam Arman Co.

Product Introduction:

Fossil energy such as oil and coal are finite and non-renewable, but new energy is not. The sun is one of the important renewable sources of energy that can be used as a useful source of energy supply in most parts of the world. The country of Iran is located in a region which receives a lot of sunlight and studies show that the use of solar equipment in Iran is suitable and can meet part of the country's energy needs. Solar radiation can be converted into electrical energy using photovoltaic systems. Photovoltaic solar cell is a system that converts solar energy into electrical energy based on the photovoltaic effect. Researchers in the field of solar cells are always looking for a way to reduce the cost of production and increase the efficiency of these cells. One of the ways is to prevent the loss of light entering the solar cell, and one of the ways to achieve this goal is to take advantage of the light scattering effect and increase the length of the travel path of incident rays and absorb more of it. In this product, the ability to increase light absorption and reduce reflection is used.

Founded:

2017

Application:

In power plants and more use of photovoltaic cells

This product is a final B2B consumer product.

Technical Specifications:

Substrate	Glass
Middle layer	MgF ₂
Outer layer	Air

Advantages:

- ※ Selection of modern solar cells for higher efficiency
- ※ The thickness suits the optical calculations
- ※ Accurate spectrometry for transmission, absorption and reflection

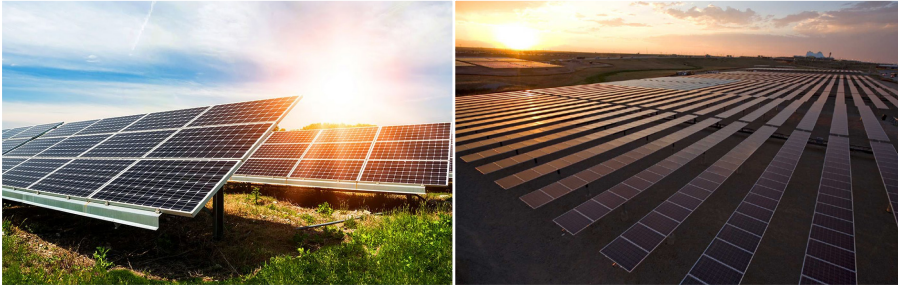

► Luminescent Solar Concentrator Module Using Bifacial Photovoltaic Cells

◆ Solar Tabesh Tavan BNL (STTB) Co.

www.solarttb.com



Product Introduction:

This product is a new type of photovoltaic solar module in the Luminescent Solar Concentrator Photovoltaic (LSC PV) category, which can convert solar radiation to electrical energy using single cube light guides connected to both sides of bifacial silicon solar cells. In both of their levels, this device traps the sun's radiation and converts its spectrum to the desired wavelength band (depending on the quantum efficiency of the solar cells) and concentrates the light by total internal reflection (TIR) and then acts on the solar cells connected to the edges and back.

Founded:

2014

Application:

Converting sunlight into electrical energy

This product is final B2B equipment.

Technical Specifications:

Power conversion efficiency: Above %17

Advantages:

- * Has improved spectral conversion features
- * Adjustable in terms of dimensions, color, transparency and shape
- * Lower cost compared to PV modules



➤ **A Research Inverter Connected to the Grid with the Ability to Extract Maximum Power from a Solar Panel or Wind Turbine**

◆ Energy Drive Spadana Co.



Product Introduction:

This product with research and semi-industrial application has one or two three-phase inverters, whose input power can be provided by a rectifier (or battery, solar panel, wind turbine, etc.) and its output can also be connected to the global power grid or feed off any other electrical load. The output load of this product has the ability to be one of the three-phase and multi-phase electric motors such as induction, PMS, BLDC. This set has a modular structure with the possibility of any generalization of hardware for the implementation of new power electronic structures used in theses of electrical engineering graduate studies, and by using a programmable digital processor, it is possible to change the create various programs needed to control the inverter, DC-DC converter and other sub-sections and record the results in the computer or oscilloscope.

Founded:
2017

Application:

- * Researches on types of electronic power structures and control methods of solar inverters connected to the grid and isolated with the ability to extract maximum MPPT power.
- * Researches on types of electronic power structures and control methods of wind turbine-based inverters (generators), connected to the grid (or isolated) with the ability to extract maximum MPPT power.
- * Researches on various types of electronic power structures and control methods of three-phase and multi-phase electric machines

This product is final B2B equipment.

Technical Specifications:

Nominal voltage of the dc link	310 volts (previous sample 750 volts)
Nominal power of the inverter	2 kW - Ampere
Nominal inverter output voltage	400 V
Range of frequency changes	40 – 60 Hz

Advantages:

- * Has three-phase output current, speed and voltage sensor and DC link
- * The possibility of online sampling and recording of the data of the system under test in the computer
- * Lower current range and larger voltage compared to similar products
- * Lower price than similar products

International Standards or Permissions:

- * BS EN 61173
- * BS EN 61194
- * BS EN 61427
- * PREN 50312-1
- * PREN 50312-2
- * IEC 61727

**Application:**

Solar cell research laboratories

➤ High Performance Electrolyte

◆ Sharif Solar Co.

www.sharifsolar.ir

**Product Introduction:**

The high-performance electrolyte consists of the oxidation/reduction pair I^-/I_3^- in acetonitrile/valeronitrile solvent. The use of this electrolyte in the solar cell makes it possible to emit light from the cathode due to its higher efficiency, and it is suitable for use in solar cells with metal anodes.

Founded:

2014

This product is a final B2B consumer product.

Technical Specifications:

Solvent	Acetonitrile/valeronitrile
Additives	~ 10%
Physical state	Liquid

Advantages:

Lower price than similar products

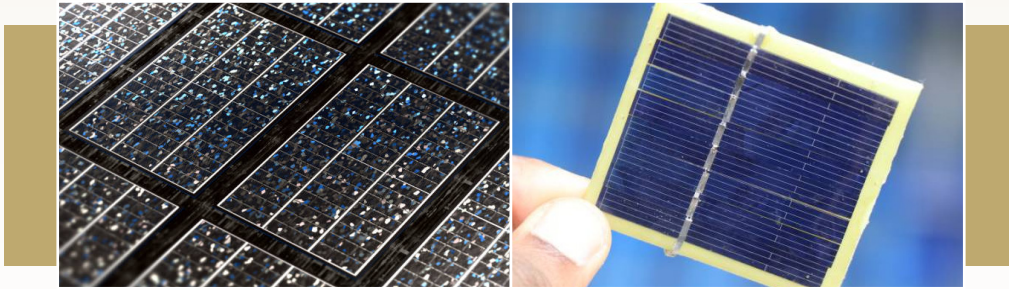

➤ Standard Electrolyte

◆ Sharif Solar Co.

www.sharifsolar.ir



Product Introduction:

The standard electrolyte contains the oxidation/reduction pair I^-/I_3^- and its solvent is acetonitrile, the solar cell based on this electrolyte has a higher current than other electrolytes, but acetonitrile is volatile and therefore a proper sealing must be used in the construction of the cell.

Founded:

2014

Application:

Solar cell research laboratories

This product is a final B2B consumer product.

Technical Specifications:

Solvent	Acetonitrile
Additives	~ 8%
Physical state	Liquid

Advantages:

Lower price than similar products

Fourth Chapter
Fuel Cells

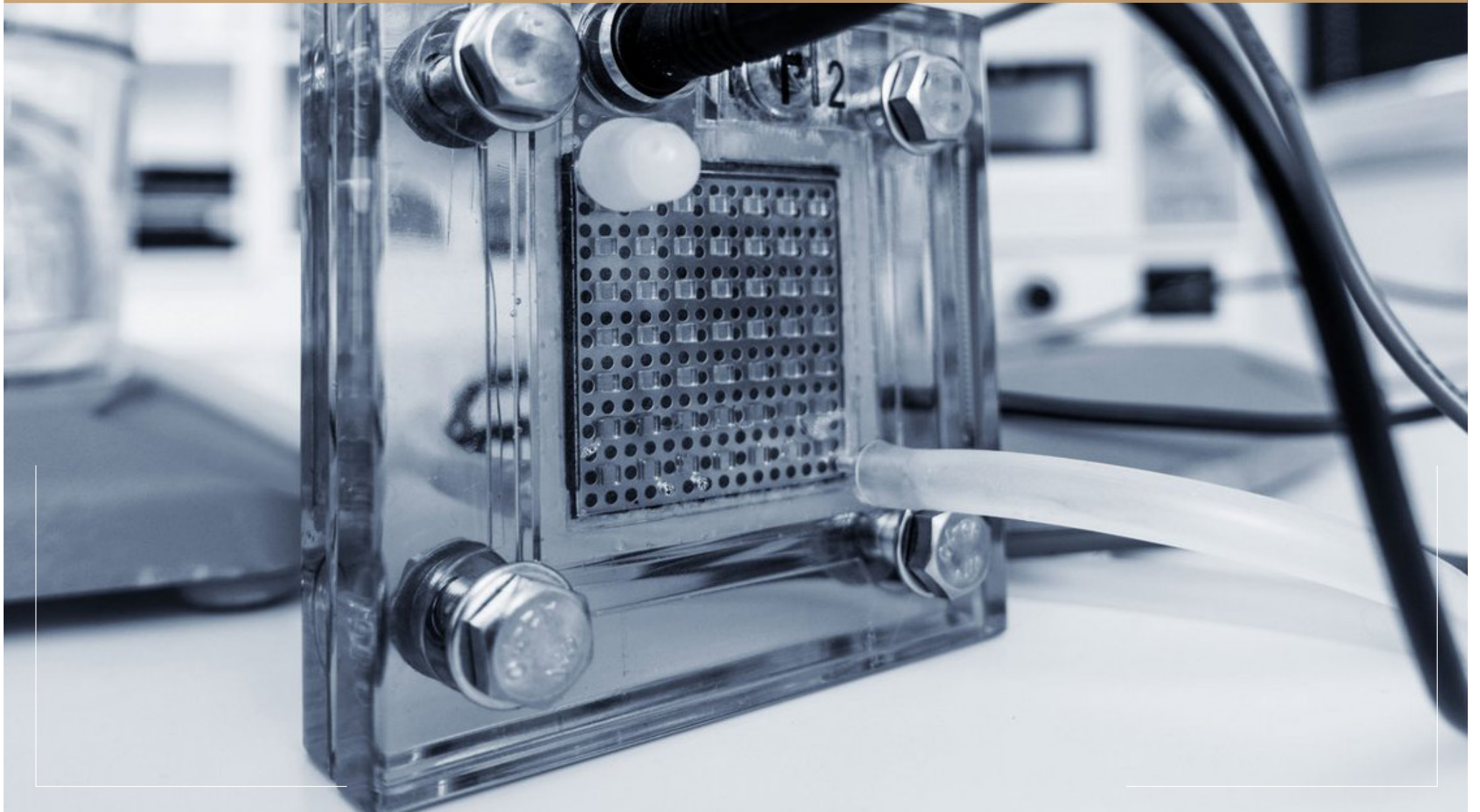

4th CHAPTER

First Chapter

Second Chapter

Third Chapter

Fourth Chapter

Fifth Chapter

Fuel Cells

Fuel Cell Stack with Design and Manufacture of Bipolar Plates, Membrane and Catalyst | 278

Membrane Humidifier for Fuel Cell | 280



➤ Fuel Cell Stack with Design and Manufacture of Bipolar Plates, Membrane and Catalyst

◆ Kimia Gohar Fine Chemicals Co.

www.kimiagohar.com

کیمیا گهر
پیشرو و سازنده

Product Introduction:

A fuel cell stack is a type of equipment that is made by putting several separate fuel cells together. In principle, in order to obtain an electric power source with the appropriate voltage and current density for the desired application, several fuel cells must be able to be placed next to each other so that the total voltage of all cells reaches the desired range. . Basically, this product is the result of the integration of the main and sub-systems by creating a proper connection between the components.

Founded:

2019

Application:

Increasing the efficiency and lifespan of polymer fuel cells

This product is final B2B equipment.

Technical Specifications:

Description of the component/ material/software and its relationship with other components	All components of the stack including electrocatalyst, membrane, bipolar plates, sealant, end plates, gas penetration layer have been prepared and then the the stack has been assembled.
Active surface of bipolar plates	100 cm ²
The ability to generate voltage	15-20 volts at currents of 50 to 70 amps

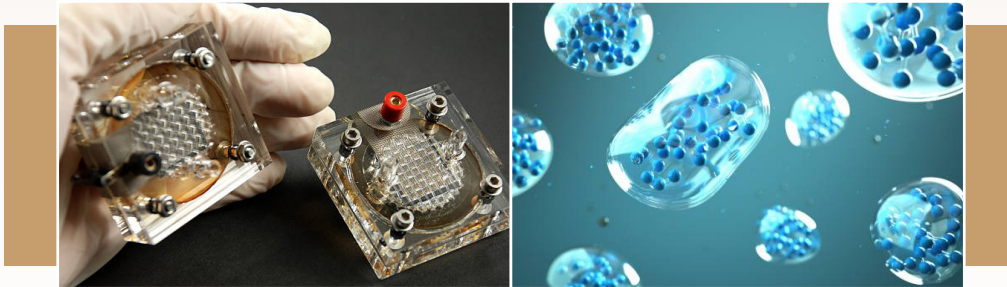
**Application:**

Increasing the efficiency and lifespan of polymer fuel cells

➤ Membrane Humidifier for Fuel Cell

◆ Pak Sun Energy Spadan Co.

www.paksunenergy.ir

**Product Introduction:**

Membrane humidifiers of Paksun Energy Espadan Company have the ability to exchange heat and moisture between two processes and also between water and another gas. Moist water or gas moves from one side and dry gas moves from the other side. In addition to being able to transfer a significant amount of moisture, this system also enables heat transfer. For this purpose, it is necessary to heat the incoming water. It is necessary to use pure water so that the system works better. During the transfer of moisture and heat to gas, this system has no moving parts, so it is very efficient in transferring energy. When the water moves in the middle plates, the Nafion membrane transfers the moisture to the other side and makes the dry gas humid. The movement of water from the wet side to the dry side is enabled by the concentration difference between the inlet and outlet. Since the movement paths of water and gas are completely separate, there is no transfer of water to the dry gas side.

Founded:

2010

This product is final B2B equipment.

Technical Specifications:

Using an intermediate layer (Nafion membrane) to transfer water and humidity to the poles of the fuel cell and as a result, increase the efficiency and performance of the cell

Advantages:

Lower price than similar products

Fifth Chapter

Batteries



5th CHAPTER

First Chapter

Second Chapter

Third Chapter

Fourth Chapter

Fifth Chapter

Batteries

Nano Barium Sulfate Used in the Battery Industry | 286

Vanadium Battery (Flow Battery) | 288

Sections

Raw Materials for Batteries ○



➤ Nano Barium Sulfate Used in the Battery Industry

◆ Nanochemistry Novin Iranian Co.

www.ncnico.ir



Product Introduction:

Synthetic barium sulfate is produced from the reaction between barium carbonate salt and nitric acid and then ammonium sulfate. For this purpose, first, 1000 liters of water is poured into the 3000-liter reactor, then barium carbonate is added into it at the same time by stirring the contents of the reactor, and after that, nitric acid must be added into the reactor. After finishing adding nitric acid, ammonium sulfate, which is already dissolved in water, is added to the reactor. By adding ammonium sulfate to the reactor, barium sulfate will be produced simultaneously. After completing this step, the contents of the reactor are stirred for 2 hours to consume raw materials that did not react. The produced product is sent to the 5000 liter reactor and washed several times with distilled water to minimize the impurities in the mixture. In each step of washing, the impurity level of the solution inside the reactor is measured, and after the electrical conductivity of the water reaches less than 150 microsiemens, the slurry is transferred to the dryer, and finally, the product is dried, milled and packed.

Application:

In the battery industry, for the formation of lead sulfate during battery charging and discharging periods

This product is a final B2B consumer product.

Founded:

2016

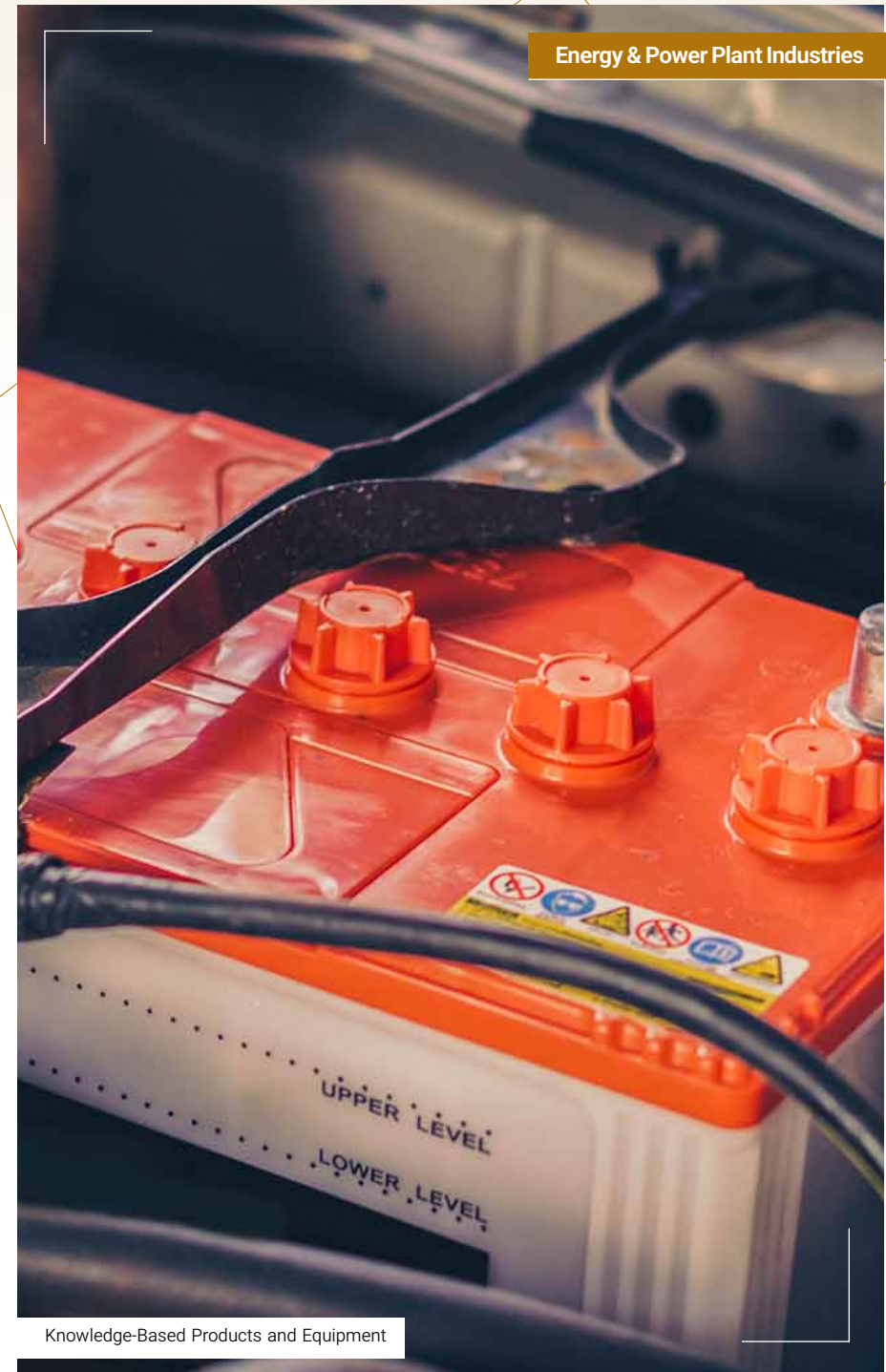

**Application:**

Used in emergencies and power outages

➤ Vanadium Battery (Flow Battery)

◆ Shimi Gostaran Elm Bavar Co.

Product Introduction:

With the passage of time and the urgent need for power supply and storage systems, energy systems has gained special importance and become more tangible. Therefore, researchers are looking for systems that can perform these two actions at the same time and have high cycleability and long life and high weighted and volume energy density. Flow batteries are batteries that produce energy based on the passage of fluid through anode and cathode stacks placed side by side as anode and cathode half-cells and separated by a separator. The advantage of these batteries is that the larger our fluid reservoirs are, the more energy we have access to, and if our stacks are larger, we have access to higher energy density. Therefore, these resources can be changed and increased. These resources are also used in passive defense. So that these energy sources can be drilled underground and can be transported to the desired place through piping and are always safe and in a suitable place and can be used in emergency situations.

*This product is a final B2B consumer product.***Technical Specifications:**

Size	* 50 × 50 mm * 100 × 100 mm
Reservoir volume	5000 cc
Material	Electrolyte
Weighted energy density	About 165 Wh/kg

Advantages:

- * High useful life
- * Ability to recharge for many times
- * Considerable electrical power per unit weigh



Iran House of Innovation and Technology (iHiT)

Iran House of Innovation and Technology (iHiT) is one of the types of export intermediaries that launched under the auspices of the Vice President for Science and Technology in Kenya, China, Russia, Turkey, Syria and Iraq. In addition to accessing the export instructions, these houses provide variety of services for companies to enter the interactional service markets such as: private and shared workspace, permanent exhibition of products, finding business partners and investing in the target countries of export, company registration, product registration, medicine, medical equipment and trademarks registration, dispatch and admission of business delegations, hiring local specialists to present products and service.

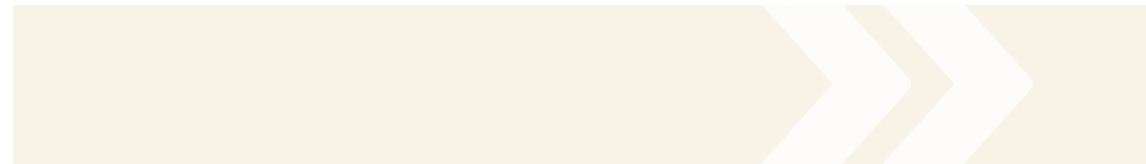



TEHRAN iHiT

Manager: Mohammad Karami

Field of Activity: Permanent International Exhibition | Export of products and services of knowledge-based, creative and technology companies in Tehran

Country: Islamic Republic of Iran – Tehran

Services:

- Holding permanent exhibition of knowledge-based products and services
- Holding specialized events and meetings
- Providing dedicated and shared workspace in Tehran
- Identifying export opportunities
- Identifying opportunities for scientific, technological and industrial cooperation

Address: Hall 37A, Tehran International Exhibition, Tehran, Iran

website: www.ihit-expo.com

Tel No: (+98) 912 444 9958 / (+98) 21 910 737 37

Supervisor: Mohammad Mahdi Agharafiee

Office Phone: (+98) 912 706 9611

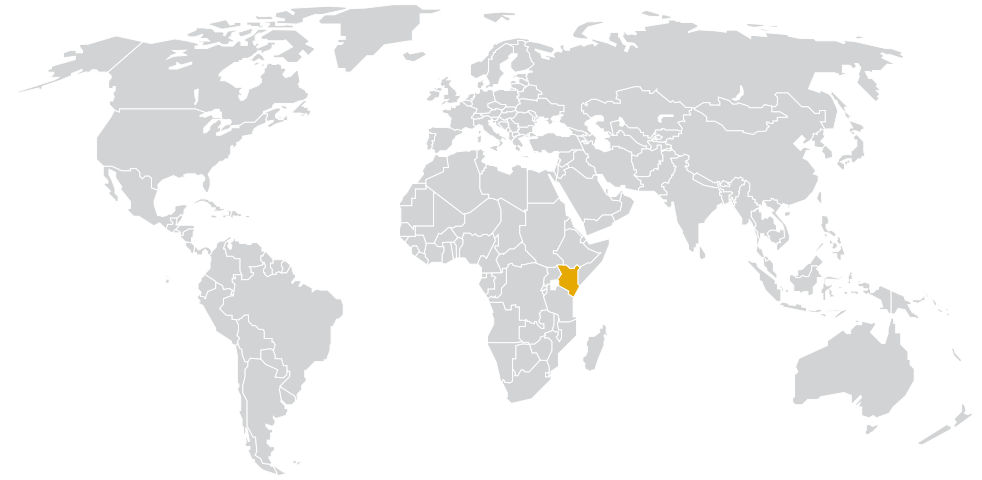

NAIROBI iHiT

Manager: Ali Baniamerian

Field of Activity: Export of products and services of knowledge-based, creative and technology companies

Country: Republic of Kenya – Nairobi

Services:

- Holding Permanent exhibition of products and services
- Providing dedicated and co-working space
- Holding the National Pavilion of the Islamic Republic of Iran in international exhibitions
- Export development of knowledge-based products
- Identifying opportunities for scientific, technological and industrial cooperation
- Providing export instructions of the Center for International Science and Technology Cooperation

Address: Dennis Pritt Road, Next to Maalim Juma Road, Kilimani, Nairobi, Kenya

website: www.ihit.co.ke

Tel No: (+254) 111 606 113

Supervisor: Fahime Zabihi

Office Phone: (+98) 21 910 700 80 INT 301



SUZHOU iHiT

Manager: Amir Ghorbanali

Field of Activity: Export of products and services of knowledge-based, creative and technology companies

Country: People's Republic of China - Shanghai

Services:

- Holding Permanent exhibition of products and services
- Export development of knowledge-based products
- Providing dedicated and co-working space
- Identifying opportunities for scientific, technological and industrial cooperation
- Holding the National Pavilion of the Islamic Republic of Iran in international exhibitions
- Providing export instructions of the Center for International Science and Technology Cooperation

Address: Room 88 ,409 Keling Road, Advanced District, Suzhou, Jiangsu Province, China

website: www.innotechexport.ir

Tel No: (+86) 182 062 123 92

Supervisor: Simin Rafeapour

Office Phone: (+98) 935 861 44 22

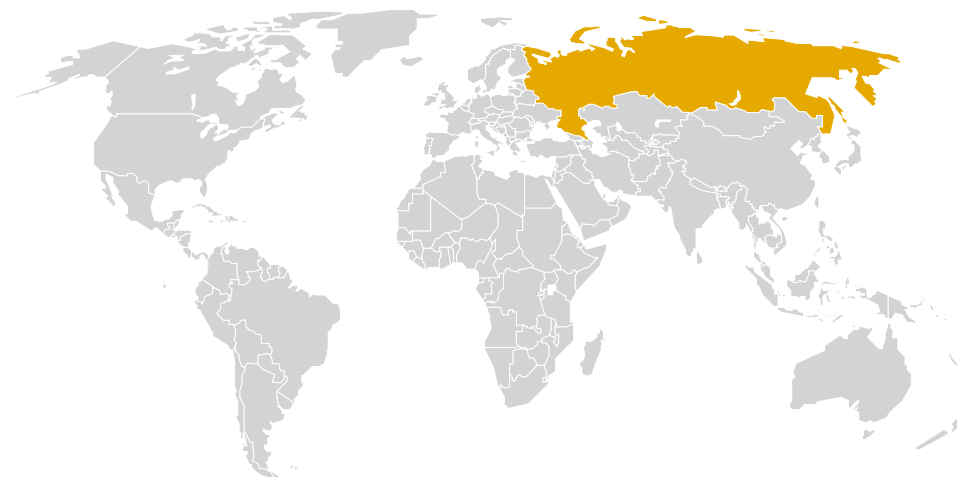

MOSCOW iHiT

Manager: Mahdi Deilam Salehi

Field of Activity: Export of products and services of knowledge-based, creative and technology companies

Country: Russian Federation – Moscow

Services:

- Holding Permanent exhibition of products and services
- Providing dedicated and co-working space
- Holding the National Pavilion of the Islamic Republic of Iran in international exhibitions
- Export development of knowledge-based products
- Identifying opportunities for scientific, technological and industrial cooperation
- Providing export instructions of the Center for International Science and Technology Cooperation

Address: No. 7, Unit 4, Arkhangelsky St., Moscow, Russian Federation

website: www.ihit-ru.com

Tel No: (+7) 903 123 16 31

Supervisor: Malek Saeidi

Office Phone: (+98) 912 617 6293 | (+98) 21 860 537 15 INT 309

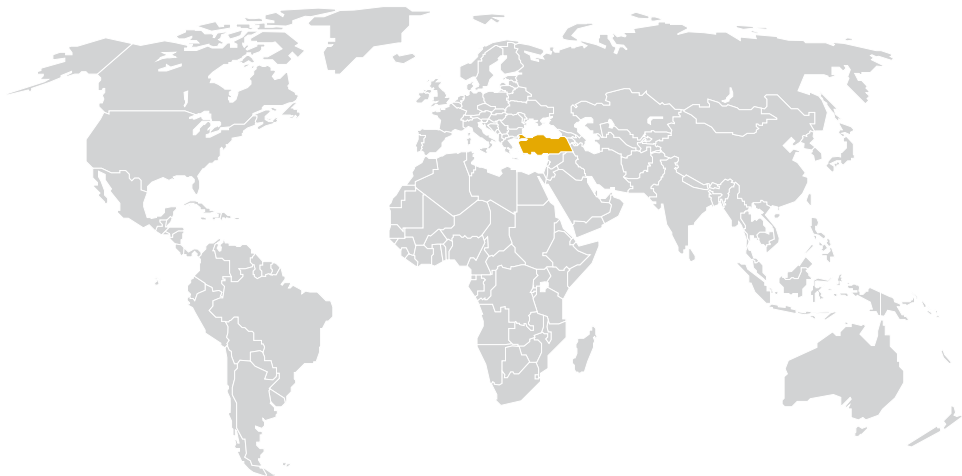

ISTANBUL iHiT

Manager: Masoud Hasani

Field of Activity: Export of products and services of knowledge-based, creative and technology companies

Country: Turkey – Istanbul

Services:

- Holding Permanent exhibition of products and services
- Providing dedicated and co-working space
- Holding the National Pavilion of the Islamic Republic of Iran in international exhibitions
- Export development of knowledge-based products
- Identifying opportunities for scientific, technological and industrial cooperation
- Providing export instructions of the Center for International Science and Technology Cooperation

Address: Halaskargazi, Halaskargazi Cd. No: 34371 ,66-38 Şişli/Istanbul

website: www.istanbulihit.com **Email:** info@istanbulihit.com

Tel No: (+90) 21 240 141 44 **Whatsapp:** (+90) 533 505 4589

Supervisor: Masoud Hasani

Office Phone: (+98) 21 882 227 55



DAMASCUS iHiT

Manager: Mohammad Hadi Zeighami

Field of Activity: Export of products and services of knowledge-based, creative and technology companies

Country: Syria – Damascus

Services:

- Holding Permanent exhibition of products and services
- Providing dedicated and co-working space
- Export development of knowledge-based products
- Identifying opportunities for scientific, technological and industrial cooperation
- Holding the National Pavilion of the Islamic Republic of Iran in international exhibitions
- Providing export instructions of the Center for International Science and Technology Cooperation

Address: Damascus Freezone, Jamarag Sq., Damascus, Syria

website: www.ihit.sy

Tel No: (+98) 918 693 39 33

Supervisor: Hasan Tahmasebi

Office Phone: (+98) 21 631 033 15

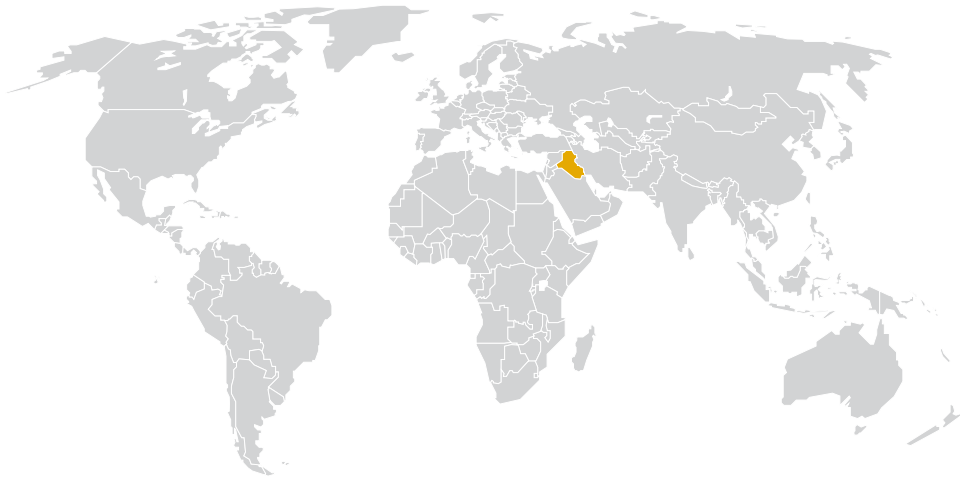

Iraq (Sulaymaniyah) iHiT

Manager: Hossein Salmani

Field of Activity: Export of products and services of knowledge-based, creative and technology companies

Country: Iraq – Sulaymaniyah

Services:

- Holding Permanent exhibition of products and services
- Providing dedicated and co-working space
- Holding the National Pavilion of the Islamic Republic of Iran in international exhibitions
- Export development of knowledge-based products
- Identifying opportunities for scientific, technological and industrial cooperation
- Providing export instructions of the Center for International Science and Technology Cooperation

Address: Iraq, Sulaymaniyah, Sever St.

website: www.abc-s.com

Tel No: (+964) 774 567 03 66

Supervisor: Mohammad Mahdi Alebouyeh

Office Phone: (+98) 939 124 5009

This book includes
selected knowledge-based Iranian products
in the field of

ENERGY & POWER PLANT INDUSTRIES

which is prepared for promotion in other countries.



www.cistc.ir



www.etdf.ir